

Operating instructions

Pushbutton sensor 4.70 Standard, 1-gang
Art. no. 5311 00

Pushbutton sensor 4.70 Standard, 2-gang
Art. no. 5312 00

Pushbutton sensor 4.70 Standard, 4-gang
Art. no. 5314 00

Pushbutton sensor 4.70 Komfort, 1-gang
Art. no. 5341 00

Pushbutton sensor 4.70 Komfort, 2-gang
Art. no. 5342 00

Pushbutton sensor 4.70 Komfort, 4-gang
Art. no. 5344 00

Table of contents

| | | |
|-----------|--|-----------|
| 1 | Safety instructions | 3 |
| 2 | Device components | 3 |
| 3 | System information | 5 |
| 4 | Intended use | 5 |
| 5 | Product characteristics | 6 |
| 6 | Operation | 6 |
| 6.1 | Examples for operating various standard applications | 7 |
| 7 | Information for electrically skilled persons | 8 |
| 7.1 | Mounting and electrical connection | 8 |
| 7.2 | Commissioning | 10 |
| 7.2.1 | Safe-state mode | 11 |
| 7.2.2 | Master reset | 11 |
| 7.3 | Mounting the rockers | 12 |
| 7.4 | Dismantling | 13 |
| 7.5 | Exchanging labelling field | 13 |
| 8 | Technical data | 14 |
| 9 | Accessories | 14 |
| 10 | Warranty | 15 |

1 Safety instructions

To avoid potential damage, read and follow the following instructions:



Electrical devices may be mounted and connected only by electrically skilled persons.

Danger of electric shock. During installation and cable routing, comply with the regulations and standards which apply for SELV circuits.

Instructions are part of the product, so keep them in a safe place.

i The technical documentation on our web site contains detailed information.

2 Device components

Front view

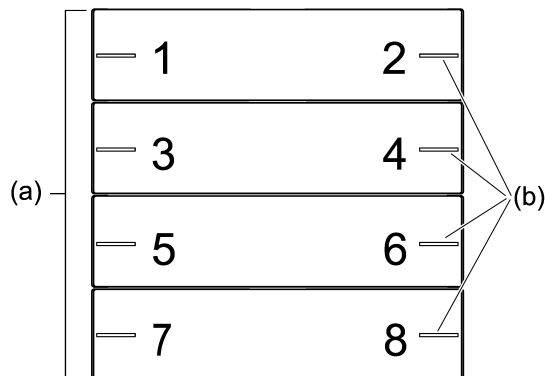

Figure 1: Device components 4-gang (installation position: "standard installation position", horizontal rockers)

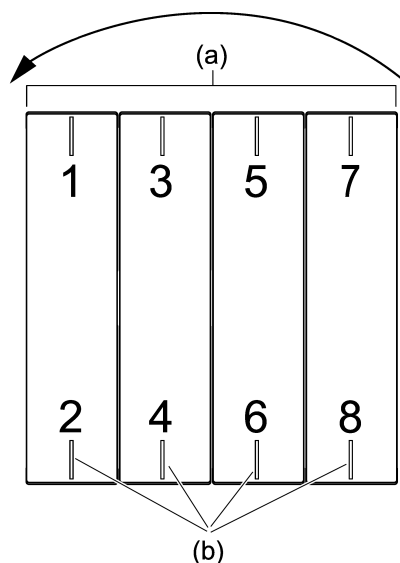

Figure 2: Device components 4-gang (installation position: "turned by -90°", vertical rockers)

(a) Operating rockers (accessory)

- (b) Status LED
- 1...8 Push-buttons assignment and status LED

Rear view

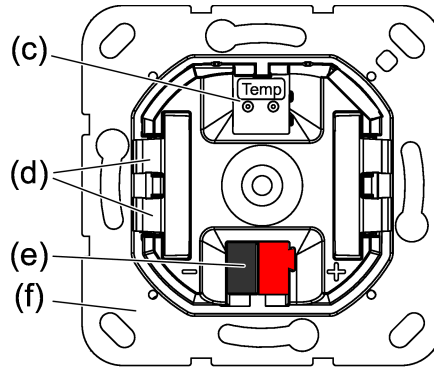

Figure 3: Device components - rear side

- (c) Device connection terminal for remote sensor (only for "Komfort" device variant)
- (d) Retaining clips for device fixation at the supporting frame
- (e) Device connection terminal, bus
- (f) Supporting frame

Button allocation ,

Rear view with supporting frame

Sensor positions, programming button and programming LED

Mounting

- (a) Operating rockers (accessory)
- (b) Status LED
- 1...8 Push-buttons assignment and status LED
- (c) Device connection terminal for remote sensor (only for "Komfort" device variant)
- (d) Retaining clips for device fixation at the supporting frame
- (e) Device connection terminal, bus
- (f) Supporting frame
- (g) Programming LED
- (h) Programming button
- (i) VOC sensor (only for "Komfort" device variant)
- (j) Temperature sensor
- (k) Supporting frame
- (l) Cover frame (accessory)
- (m) Push-button sensor
- (n) Box screws

3 System information

This device is a product of the KNX system and complies with the KNX directives. Detailed technical knowledge obtained in KNX training courses is a prerequisite for proper understanding.

The function of the device depends on the software. Detailed information on software versions and the respective scope of functions as well as the software itself can be obtained from the manufacturer's product database.

The device can be updated. Firmware can be easily updated with the Gira ETS Service App (additional software).

The device is KNX Data Secure capable. KNX Data Secure offers protection against manipulation in building automation and can be configured in the ETS project. Detailed technical knowledge is a prerequisite. A device certificate, which is attached to the device, is required for safe commissioning. During mounting, the device certificate must be removed from the device and stored securely.

Planning, installation and commissioning of the device are carried out with the aid of the ETS, version 5.7.7 and higher or 6.3.0.

4 Intended use

- Operation in KNX system
- Operation of loads, e.g. light on/off, dimming and colour temperature control, colour control and brightness, shading up/down, 1-byte values, 2-byte values, 3-byte values and 6-byte values, brightness values, temperatures, colour temperature values, calling up and saving light scenes as scene extension
- Calling up and saving device-internal light scenes
- Measurement of room temperature
- Measurement of the room humidity (only for "Comfort" device variant)
- Measuring the air quality (only with "Comfort" device variant)
- Indication of an alarm (only for "Comfort" device variant)
- For use as orientation lighting
- Mounting in appliance box with dimensions according to DIN 49073
- Horizontal installation position in the "standard installation position" or vertical installation position in the "turned by -90°" installation position

5 Product characteristics

| Product characteristic per product variant | Comfort | Standard |
|--|---------|----------|
| Push-button sensor functions switching, dimming and colour temperature control, colour control and brightness, Venetian blind, value transmitter, scene extension, 2-channel operation and controller extension adjustable | ✓ | ✓ |
| Controller extension with operating mode selection, forced operating mode switch over, presence function and setpoint shift | ✓ | ✓ |
| Status LED – optionally red, green, blue - adjustable per button | ✓ | ✓ |
| Status LED - optionally red, green, blue, yellow, cyan, orange, violet, white - adjustable per button | ✓ | - |
| LED functions orientation lighting and night reduction can be set separately | ✓ | ✓ |
| Alarm message LED function can be set separately | ✓ | - |
| Brightness of LED adjustable and switchable while in operation | ✓ | ✓ |
| Disable or function switch-over of all or of individual button functions possible with disabling function | ✓ | ✓ |
| Scene control of up to 8 scenes with 8 scene outputs each | ✓ | - |
| Temperature measurements optionally with device internal sensor and external sensor connected via communication object | ✓ | ✓ |
| Temperature measurements optionally with device internal sensor, wired sensor to the device connection terminal and external sensor connected via communication object | ✓ | - |
| Room humidity measurement with internal device humidity sensor | ✓ | - |
| Air quality measurement with internal VOC sensor | ✓ | - |
| Integrated bus coupling unit | ✓ | ✓ |

6 Operation

Depending on the programming, a rocker can have up to two functions assigned to it. Operation is carried out by a short or long press on the push-buttons and depends on the specific function configured.

6.1 Examples for operating various standard applications

- Switch: Short press on button.
- Dim: Long press on button. The dimming process ends when the button is released.
- Move Venetian blind: Long press on button.
- Stop or adjust Venetian blind: Short press on button.
- Set value, e.g. brightness or temperature setpoint: Short press on button.
- Open scene: Short press on button.
- Save scene: Long press on button.
- Execute channel 1: Short press on button.
- Execute channel 2: Long press on button.
- Operate controller extension: Short press on button.

7 Information for electrically skilled persons

7.1 Mounting and electrical connection



DANGER!

Electric shock when live parts are touched.

Electric shocks can be fatal.

Cover up live parts in the installation environment.

The push-button sensor (see figure 4) can be installed horizontally ("standard installation position") or vertically ("turned by -90°" installation position).

- i** For horizontal installation ("standard installation position") the top of the push-button sensor is labelled with TOP.
- i** For vertical installation ("turned by -90°" installation position) the left side of the push-button sensor is labelled with TOP.

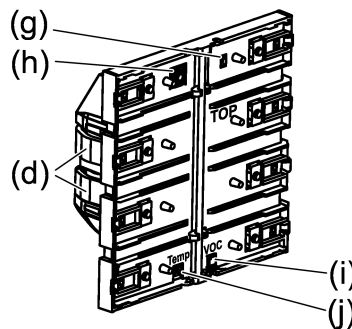

Figure 4: Push-button sensor

- (d) Retaining clips for device fixation at the supporting frame
- (g) Programming LED
- (h) Programming button
- (i) VOC sensor (only for "Komfort" device variant)
- (j) Temperature sensor

Mounting and connecting the device

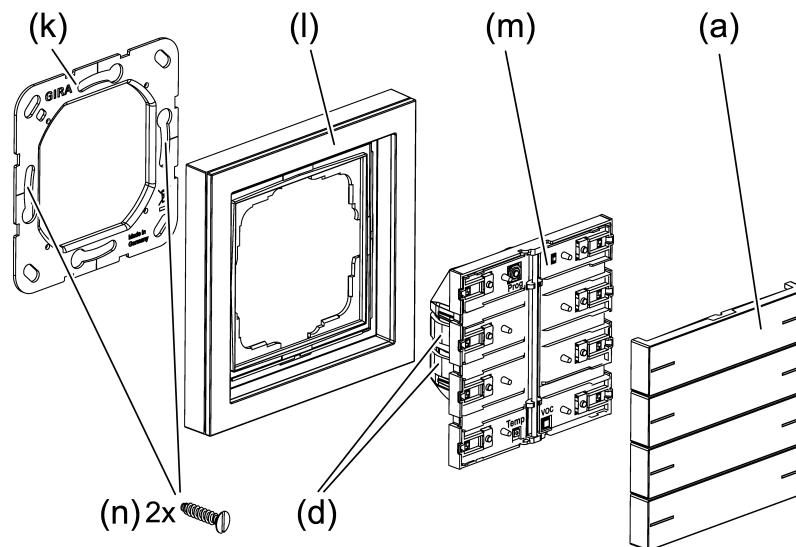

Figure 5: Mount device

- (a) Operating rockers (accessory)
- (d) Retaining clips for device fixation at the supporting frame
- (k) Supporting frame
- (l) Cover frame (accessory)
- (m) Push-button sensor
- (n) Box screws

The device should be used in an air-tight appliance box. Otherwise temperature and humidity reading can be negatively influenced by draughts.

Precondition: The installation position of the push-button sensor is defined.

- Mount supporting frame in the right orientation, "standard installation position" or "turned by -90°", on an appliance box.

Note the TOP marking.

Use the enclosed box screws.

- Connect push-button sensor to the KNX using KNX device connection terminal (red = +, black = -).
- In secure operation, the device certificate must be removed from the device and stored securely.
- Optional (only for "Komfort" device variant): Connect remote sensor (see accessories) to the connection for the remote sensor. The relevant device connection terminal is included with the remote sensor.
- Pull off commissioning rockers from push-button sensor.

The push-button sensor is delivered with commissioning rockers. The operating rockers suitable for the push-button sensor must be ordered separately (see accessories).

- Fit the cover frame flushly. The cover frame is fixed via the push-button sensor.
- Attach the push-button sensor with cover frame onto the supporting frame. Push-button sensor can be put into operation.

Make sure that the retaining clips properly fit in the supporting frame.

The physical address is programmed (see chapter "Commissioning" ▶ Page 10) in the next work step. The rockers can then be mounted (see chapter "Mounting the rockers" ▶ Page 12).

7.2 Commissioning

Programming the physical address and application program

- i** Project design and commissioning with ETS version 5.7.7 and higher or 6.3.0.

In secure operation (prerequisites):

- Secure commissioning has been activated in the ETS.
- Device certificate entered/scanned or added to the ETS project. A high resolution camera should be used to scan the QR code.
- Document all passwords and keep them safe.

The programming button is located under the first rocker.

Precondition: The device is connected and ready for operation.

The first rocker is dismantled.

- Activating Programming mode: push the programming button.
The programming LED lights up red. Programming mode is activated.
- Programming the physical address.
The programming LED goes out. Physical address is programmed.
- Programming the application program.
The device is for use.

- i** While the application programme is being programmed, the status LEDs can be switched off temporarily. As soon as the programming is successfully completed, the status LEDs carry out their parameterised function.

- i** Only for "Comfort" device variant: When the application program is discharged and the bus voltage is connected, all status LEDs initially light up white. Whenever a button is actuated, the respective illuminated status LED changes colour (white → red → green → blue → yellow → cyan → orange → violet → white → ...).

- i** Only for "standard" device variant: When the application program is discharged and the bus voltage is connected, all status LEDs initially light up green. Whenever a button is actuated, the respective illuminated status LED changes colour (green → red → blue → green → ...).

7.2.1 Safe-state mode

The safe-state mode stops the execution of the loaded application program.

If the device does not work properly - for instance as a result of errors in the project design or during commissioning - the execution of the loaded application program can be halted by activating the safe-state mode. The device remains passive in safe-state mode, since the application program is not being executed (state of execution: terminated).

Only the system software of the device is still functional. ETS diagnosis functions and programming of the device are possible.

Activating safe-state mode

- Switch off the voltage.
- Press and hold down the programming button.
- Switch on voltage.

Safe-state mode is activated. The programming LED flashes slowly (approx. 1 Hz).

Release the programming button only after the programming LED starts flashing.

Deactivating safe-state mode

- Switch off the voltage or carry out ETS programming.

7.2.2 Master reset

The master reset restores the basic device settings (physical address 15.15.255, firmware remains in place). The device must then be recommissioned with the ETS.

- i** In secure operation: A master reset deactivates device security. The device can then be recommissioned with the device certificate.
- i** Devices can be reset to factory settings with the ETS Service App. This function uses the firmware contained in the device that was active at the time of delivery (delivered state). Restoring the factory settings causes the devices to lose their physical address and configuration.

If the device - for instance as a result of errors in the project design or during commissioning - does not work properly, the loaded application program can be deleted from the device by performing a master reset. The master reset resets the device to delivery state. Afterwards, the device can be put into operation again by programming the physical address and application program.

Performing a master reset

Prerequisite: The safe-state mode is activated.

- Press and hold down the programming button for > 5 seconds until the programming LED starts flashing quickly.
- Release the programming button.

The device performs a master reset. The programming LED is switched on.

The device restarts and is in delivery state.

7.3 Mounting the rockers

- Position the rocker (a) straight (see figure 6).

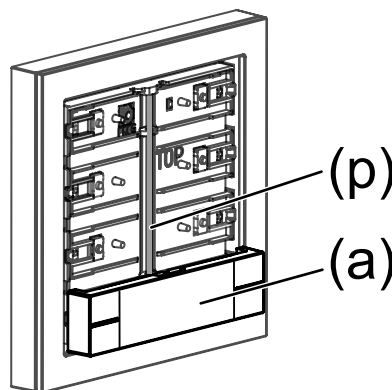

Figure 6: Position rocker straight

- Push the rocker (a) into place on the axis (p) by pressing the centre of the rocker (a) (labelling field) (see figure 7).

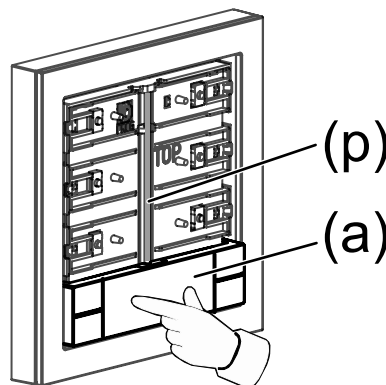

Figure 7: Press lightly in the middle of the rocker

Rocker (a) engages on axis (p) (see figure 7).

Device is ready for operation.

- i** In order to optimise the gap dimensions between the rockers and the cover frame, the rockers can be moved slightly after snapping into place.

7.4 Dismantling

- Carefully pull the push-button sensor forward together with the cover frame.
- Pull the rockers on one side to loosen them from the push-button sensor.

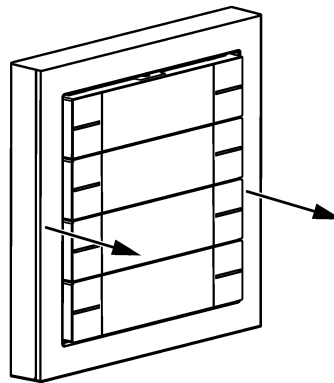

Figure 8: Dismantle the push-button sensor

7.5 Exchanging labelling field

The rocker has a labelling field

- Search for a notch in the cover of the labelling field by feeling with a finger (see figure 9).
- Pull on one side at the notch in the cover of the labelling field to separate from the rocker (see figure 10).

The labelling field is uncovered.

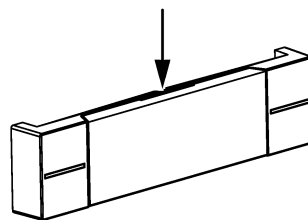

Figure 9: Feel for a notch in the labelling field cover

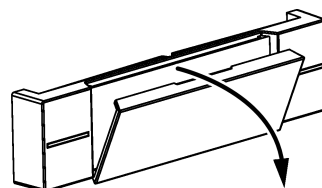

Figure 10: Remove the labelling field cover

- Exchange the labelling field.
- Press the cover of the labelling field onto the rocker so that it snaps into place.

The labelling field is exchanged.

8 Technical data

Ambient conditions

Ambient temperature -5 ... +45 °C

Storage/transport temperature -20 ... +70 °C

Relative humidity 5 ... 95% (no moisture condensation)

Protection class III

Connection cable remote sensor (see accessories)

Cable type extension NYM-J 3×1.5 or
J-Y(St)Y 2×2×0.8

Total length remote sensor line Max. 30 m

Installation dimensions (see figure 11)

Construction height A = 13.8 mm

Installation depth B = 16.2 mm

KNX

KNX medium TP256

Commissioning mode S mode

Rated voltage DC 21 ... 32 V SELV

Current consumption KNX 8 ... 22 mA

Connection mode KNX Standard device connection terminal

Connecting cable KNX EIB-Y (St)Y 2x2x0.8

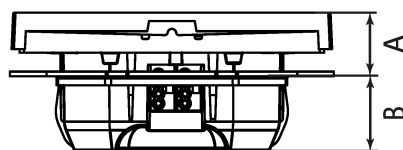

Figure 11: Installation dimensions

9 Accessories

- i** Individually labelled rocker sets are available from the Gira inscription service www.beschriftung.gira.de.

Remote sensor

Order no. 1493 00

10 Warranty

The warranty is provided by the specialist trade in accordance with statutory requirements. Please submit or send faulty devices postage paid together with a fault description to your responsible salesperson (specialist trade / installation company / electrical specialist trade). They will forward the devices to the Gira Service Center.

Gira
Giersiepen GmbH & Co. KG
Elektro-Installations-
Systeme

Industriegebiet Mermbach
Dahlienstraße
42477 Radevormwald

Postfach 12 20
42461 Radevormwald

Deutschland

Tel +49(0)21 95 - 602-0
Fax +49(0)21 95 - 602-191

www.gira.de
info@gira.de