

Installation and  
Operating Instructions

**Built-In Loudspeaker**  
1258 00

**GIRA**

## Device description

---

With the built-in loudspeaker, the Gira Door Communication System is integrated in letterbox systems, speech compartments, door side installations or front panels. The built-in loudspeaker assumes the function of a door station. It has two mounting openings which are matched to the mounting systems of common installation solutions.

Up to 8 mechanical bell buttons can be connected to the built-in loudspeaker. Additional bell buttons can be connected via add-on modules. It is possible to connect up to 11 add-on modules with 12 bell buttons each. With these door communication systems with up to 70 audio devices can be realised, e.g.

- 1 Audio control device
- 1 Built-in speaker with
- 5 Add-on modules
- 68 Surface-mounted, hands-free feature home stations



### **Number of devices**

The Gira door communication system is designed for the following numbers of devices:

Audio: 70 devices, Video: 20 devices.

## Device presentation

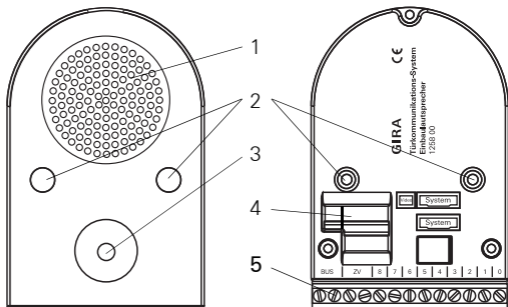

### Front

- 1 Loudspeaker
- 2 Mounting opening
- 3 Microphone

### Back

- 4 Interfaces  
System: Connection for add-on module or other system components  
Video: Connection of the UP colour camera
- 5 Terminal strip  
BUS: Connection to the 2-wire bus  
ZV: Supply of UP colour camera etc.  
0: Common earth for bell buttons  
1 - 8: Connection for bell buttons



### Attention

Installation and mounting of electrical devices may only be carried out by a qualified electrician.

The built-in loudspeaker is mounted behind the speech cover plate of the existing system. Depending on the design, this is carried out directly on the front panel or via an installation carrier.

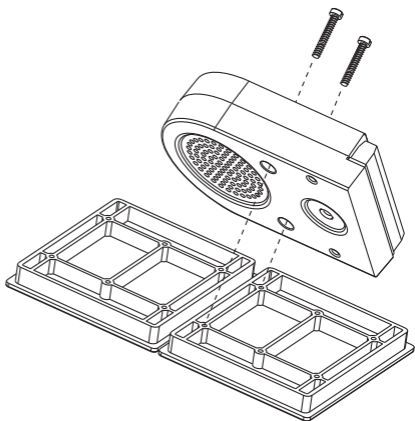

Use only the screws provided to mount the built-in loudspeaker.

When positioning the built-in loudspeaker, make sure that both the microphone and the loudspeaker are mounted in front of the sound openings. Here the position of the microphone should be given a higher priority.

The best speech quality is achieved when a separating bar is located between the loudspeaker and the microphone.

## Connection

---

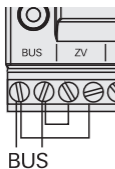

1. Connect the 2-wire bus to the BUS terminals.
2. If necessary, fit jumpers between the BUS and ZV terminals. This is necessary when illuminated system components or a colour camera are to be operated on the built-in loudspeaker.

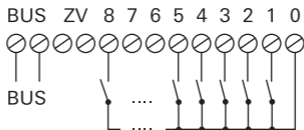

3. Connect the bell buttons. The maximum cable length is 2 m.



#### **Do not connect "0" terminal**

When using an add-on module, the "0" terminal of the built-in loudspeaker may not be connected to the "0" terminal of the add-on module.

4. If necessary, connect additional components from the door communication system via the "System" or "Video" slots.



#### **Illumination of bell buttons**

The illumination of the bell buttons cannot be supplied via the bus system of the door communication system.

Use an additional power supply for the bell button illumination.

## Connecting door communication components

Due to the full compatibility of the built-in loudspeaker to the door communication system, flush-mounted inserts, such as a colour camera, info module or call buttons, can also be connected.

### Colour camera

1. Connect the flush-mounted insert of the colour camera with the built-in speaker using the 2-pole video connection cable and the 6-pole audio connection cable.
2. Fit jumpers between the BUS and ZV terminals on the built-in loudspeaker.

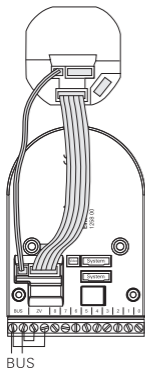

### Info module, call button

1. Connect the flush-mounted insert of the device to the built-in loudspeaker using the 6-pole audio connection cable.
2. To activate the illumination of the info module or the call button, fit jumpers between the BUS and ZV terminals on the built-in loudspeaker.

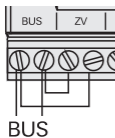

Once you have installed all of the devices (built-in loudspeaker, home station, control device etc.), you can put the door communication system into operation.

Commissioning is described in the system manual included with the control device.



### Note

When commissioning large systems, please note that a maximum of 20 bell buttons can be temporarily stored per work step. If more than 20 bell buttons are installed, at first the initial 20 bell buttons must be assigned to the home stations. Then the next 20 or the remaining bell buttons are assigned.



### Volume setting

The volume can be set separately at each door station.

The volume setting must be made by two people.



1. Start programming mode at the **control device** by pressing the "System progr." button for 3 seconds until the yellow LED next to the button starts flashing.

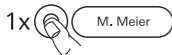

2. Briefly press a previously assigned bell button at the **door station**.



3. The second person accepts the door call at the **home station** (via receiver or speech button) and starts speaking.

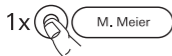

4. Briefly press the bell button at the **door station** again.



? The volume changes when the button is pressed during the voice connection. There are four volume levels in total. The next-highest volume is set with each button press. When the loudest volume level is reached, the next button press sets the quietest volume level.



5. End the voice connection.  
The most recently set volume level is saved in the door station.



6. Exit programming mode at the **control device** by briefly pressing the "System progr." button.

## Acceptance of guarantee

---

We accept the guarantee in accordance with the corresponding legal provisions.

Please return the unit postage paid to our central service department giving a brief description of the fault.

Gira

Giersiepen GmbH & Co. KG

Service Center

Dahlienstraße 12

42477 Radevormwald

Germany

Gira  
Giersiepen GmbH & Co. KG  
P.O. Box 1220  
42461 Radevormwald  
Tel +49 21 95- 602-0  
Fax +49 21 95- 602-339  
info@gira.de  
www.gira.com

# **GIRA**