

Power supply, 640 mA uninterruptible

Order-No. : 1079 00

Operating instructions**1 Safety instructions**

Electrical equipment may only be installed and fitted by electrically skilled persons.

Failure to observe the instructions may cause damage to the device and result in fire and other hazards.

Risk of explosion! Do not throw batteries into fire.

These instructions are an integral part of the product, and must remain with the end customer.

2 Device components

Figure 1

- (1) Connection of mains
- (2) LED **230 V OK**, green
On: mains voltage present
Off: No mains voltage
- (3) LED **OK**, green
On: Battery is connected and ready for operation
Flashes: Battery polarity reversed or defective battery
Off: Battery fault, battery empty or no battery connected
- (4) Temperature sensor connection + / -
- (5) Battery connection - / +
- (6) LED **ON**, green
On: Normal operation
Off: Fault
- (7) LED **Überlast**, red
On: Overload or short-circuit on bus line
Flashes: Overvoltage on bus line
- (8) KNX connection
- (9) Reset push-button: Reset begins when the push-button is pressed and lasts 20 seconds, irrespective of the length of operation

- (10) LED **Reset**, red
On: Reset active on KNX output
- (11) Signal contact fault
- (12) Signal contact power supply
- (13) Signal contact normal operation

3 Function

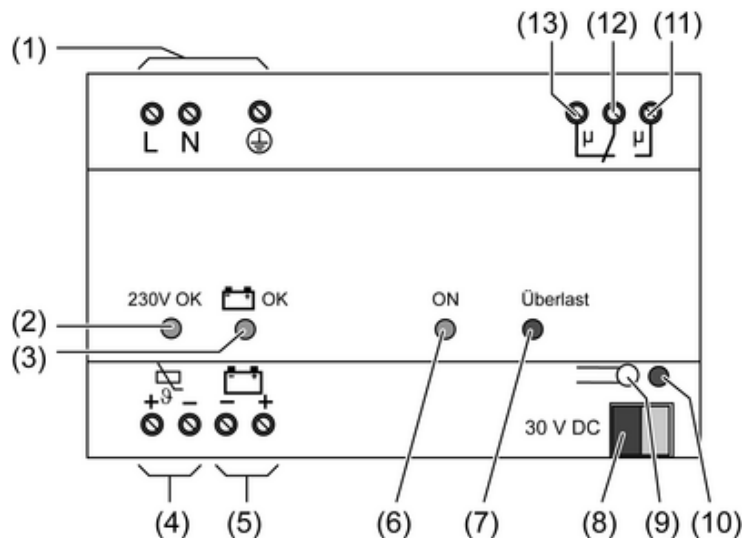
Intended use

- Supplying KNX devices with bus voltage
- Interruption-free operation of the bus line in the event of power failure with rechargeable battery
- Mounting on DIN rail according to EN 60715 in distribution boxes

Product characteristics

- Generation and monitoring of the KNX bus voltage
- With lead acid battery and cable set (see chapter 5.3. Accessories): buffering of the KNX bus voltage in the event of mains failure
- up to 2 batteries can be connected
- Short-circuit proof
- Overvoltage proof
- Integrated throttle
- Alarm contact for fault message

 The typical service life of lead acid batteries is 5 years. Because the possible mains failure bridging time is reduced in proportion with the increasing age of the batteries, the connected batteries should be exchanged every 4 years.

 Only connect specified batteries (see chapter 5.3. Accessories). Other batteries only on request.

4 Information for electrically skilled persons

4.1 Fitting and electrical connection



DANGER!

Electrical shock when live parts are touched.

Electrical shocks can be fatal.

Before working on the device, disconnect the power supply and cover up live parts in the working environment.

Fitting the device

Observe the temperature range. Ensure sufficient cooling.

- Mount the device on DIN rail. The terminals for the mains connection (1) must be at the top.

Connecting the device to mains voltage and bus

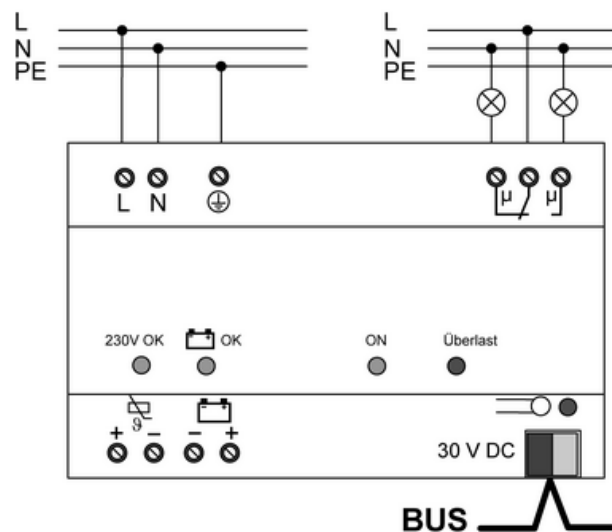

Figure 2: Connection – Overview

- Connecting the mains voltage to the terminals **L** and **N** (1).
 - Connect the protective conductor **PE** to the terminal \ominus .
 - Connect KNX bus line to output **30 V DC** (8).
- i** A KNX bus line can be supplied from two power supply units. There must be at least 200 m of bus line between the infeed points.

Connecting the battery

To connect the batteries, use only the 4-wire and 2-wire cable sets (see chapter 5.3. Accessories). Both cable sets have a fuse; the 4-wire cable set has an additional temperature sensor.



WARNING!

Risk of chemical burns.

Batteries can burst and leak.

Only use batteries of the same type.

Always exchange all batteries at the same time.

Replace batteries only with identical or equivalent types.

Insert batteries with the correct polarity.

- Connect battery and temperature sensor according to the following tables. Ensure correct colour assignment!
 - Fix temperature sensor on battery housing, e.g. with adhesive tape.
- i** Batteries with a total charge < 5 Ah are connected in a different way. Information on this is provided in the product documentation.

Connection of a battery with a charge > 5 Ah (Figure 3)

Terminal	Connection	Colour
⚡ Ⓢ+ (4)	Temperature sensor	white / WH
⚡ Ⓢ- (4)	Temperature sensor	yellow / YE
🔋- (5)	Battery -	black / BK
🔋+ (5)	Battery +	red / RD

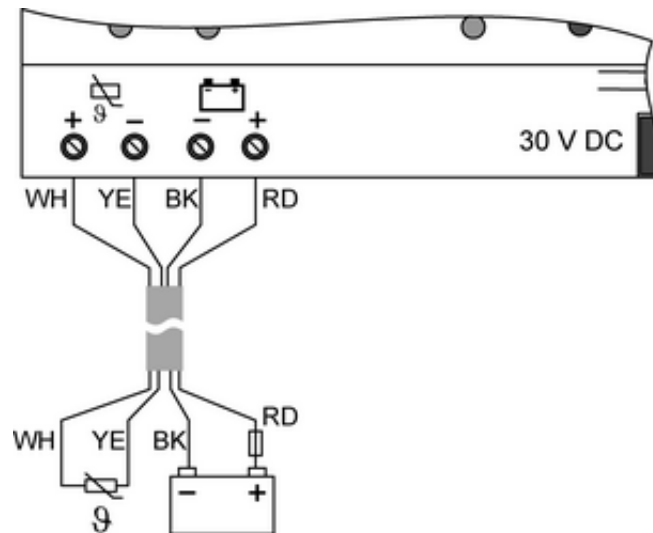

Figure 3: Connection of a battery > 5 Ah with a 4-wire cable set

Connection of two batteries with a charge > 5 Ah (Figure 4)

Terminal	Connection	Colour
⚡ Ⓢ+ (4)	Temperature sensor	white / WH
⚡ Ⓢ- (4)	Temperature sensor	yellow / YE
🔋- (5)	both batteries -	black / BK
🔋+ (5)	both batteries +	red / RD

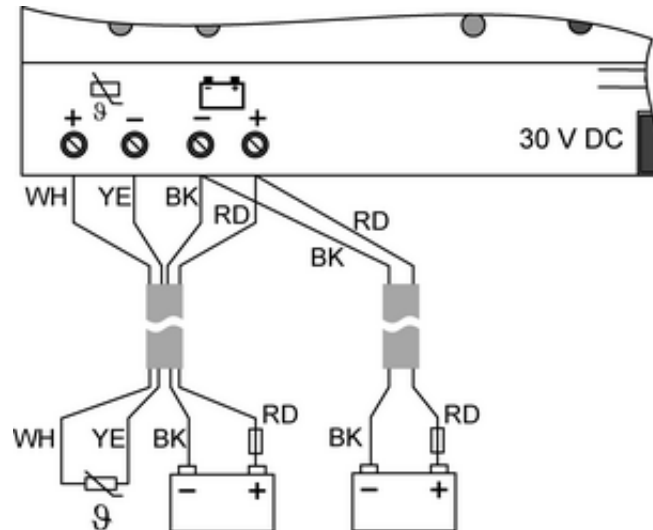

Figure 4: Connection of two batteries > 5 Ah with 4-wire and 2-wire cable set

Connecting the fault indicator

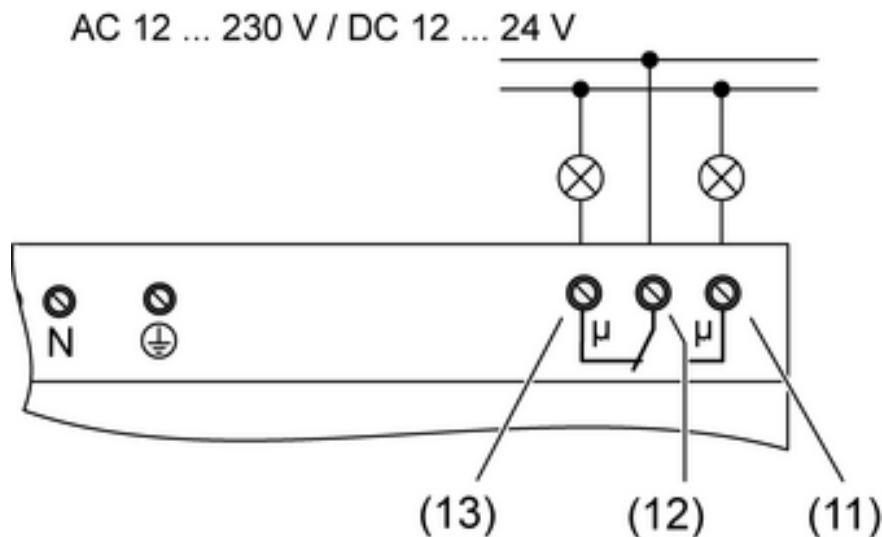

Figure 5: Connection of external fault indicator

The interruption-free power supply detects mains failure, battery failure, overvoltage, overload and reports these operational faults using a change-over contact. A monitoring device can detect the fault and forward it.

- Connect detector for normal operation to terminals (12) and (13).
- Connect detector for fault to terminals (12) and (11).

4.2 Commissioning

Commissioning the device

- Switch on mains voltage.
LEDs **ON** (6) and **230 V OK** (2) light up.
If a battery is connected: LED **BATT OK** (3) lights up.

i The device checks the connected battery every 15 minutes. The updating of the reporting status – battery error or fault-free operation – takes place within these 15 minutes.

Trigger battery test manually

If necessary a battery test can be triggered manually. This resets the bus line and all connected devices.

- Press reset push-button (9).

The bus voltage is switched off for 20 seconds and the bus line is short-circuited.





The Reset LED (10) lights up for 20 seconds.

After conclusion of the battery test the LED indicates that the battery is in an error-free state with OK (3).

5 Appendix

Remove batteries at the end of their service life and dispose of in an environmentally friendly manner. Do not throw batteries into household waste. Consult your local authorities about environmentally friendly disposal. According to statutory provisions, the end consumer is obligated to return used batteries.

5.1 Technical data

Supply	
Rated voltage	AC 195 ... 255 V ~
Rated frequency	45 ... 65 Hz
Power consumption	max. 50 VA
Power loss	max. 10 W
Ambient conditions	
Ambient temperature	-5 ... +45 °C
Storage/transport temperature	-25 ... +70 °C (Storage above +45 °C reduces the lifetime.)
KNX	
Bus output voltage	DC 28 ... 31 V SELV
Output current	640 mA (Short-circuit proof)
Short-circuit current	max. 1.4 A
Connection, Bus	Connection terminal
Connection of fault indicator	
Switching voltage	AC 12 ... 230 V~
Switching voltage DC	DC 12 ... 24 V
Switching current AC	max. 6 A
Switching current DC	max. 4 A
Battery connection	
Cable length	approx. 2 m
Fine-wire fuse	D 6.3 H 250
Rated voltage	DC 12 V
Rated charging current 1	650 mA ( + /  -)
Rated charging current 2	150 mA ( + /  -)
Mains failure bridging time (battery like new)	
1 battery 12 V / 12 Ah	approx. 5.5 h
2 batteries 12 V / 12 Ah	approx. 11 h
Housing	
Fitting width	144 mm / 8 modules
Weight	approx. 500 g
Connections	
Connection mode	Screw terminal
Single stranded	0.5 ... 4 mm ²
finely stranded with conductor sleeve	0.2 ... 2.5 mm ²

5.2 Troubleshooting

LED **Überlast (7)** flashes red. The contact (11) indicates a fault.

Cause: Overvoltage on bus line.

Eliminate cause of overvoltage.

Acknowledge fault by pressing the reset button (9).

Reset bus line by pressing the reset button (9) again.

- i** Any overvoltages that appear are saved. The device automatically performs a bus reset: The bus line is disconnected from voltage for 20 seconds and the bus line is short-circuited. During this time the reset LED (10) is lit up.

LED **Überlast (7)** lights up red. The contact (11) indicates a fault.

Cause 1: Overload or short-circuit on bus line.

Reduce number of bus devices.

Check bus line.

Acknowledge fault by pressing the reset button (9).

Reset bus line by pressing the reset button (9) again.

Cause 2: The Reset switch has been actuated on a second power supply or a separate throttle on the bus line.

Eliminate reset. Correct installation if necessary.

- i** If the bus line is overloaded the LED **Überlast** (10) lights up. If the load current exceeds 1.2 A, the bus voltage is reduced, the **ON** LED goes out. The fault is saved. If the overload lasts for longer than 10 seconds, the contact (11) indicates the fault.

LED **230 V OK** does not light up. The contact (11) indicates a fault.

Cause: Mains voltage has failed.

Check mains fuses, switch on if necessary.

Check mains supply cable and connections.

The LED **OK** blinks. The contact (11) indicates a fault.

Cause 1: Battery defective.

Exchange battery.

Acknowledge fault by pressing the reset button (9).

Reset bus line by pressing the reset button (9) again.

Cause 2: Battery polarity reversed.

Correct connection.

Acknowledge fault by pressing the reset button (9).

Reset bus line by pressing the reset button (9) again.

LED **OK** does not light up. The contact (11) indicates a fault.

Cause 1: Connecting cable to battery is interrupted or defective.

Check connection of the battery.

Cause 2: Battery fuse in cable set has tripped.

Exchange battery fuse in cable set.

Cause 3: The battery is defective.

Exchange battery.

Acknowledge fault by pressing the reset button (9).

Reset bus line by pressing the reset button (9) again.

In the event of simultaneous failure of the mains voltage: Activate mains voltage. Charge battery. Check and correct connection of battery if necessary or exchange battery.

5.3 Accessories

Lead-gel rechargeable accumulator 12 Ah
Basic cable set
Expansion cable set

Order-No. 1130 00
Order-No. 1128 00
Order-No. 1129 00

5.4 Warranty

The warranty is provided in accordance with statutory requirements via the specialist trade.

Please submit or send faulty devices postage paid together with an error description to your responsible salesperson (specialist trade/installation company/electrical specialist trade). They will forward the devices to the Gira Service Center.

Gira
Giersiepen GmbH & Co. KG
Elektro-Installations-
Systeme

Industriegebiet Mermbach
Dahlienstraße
42477 Radevormwald

Postfach 12 20
42461 Radevormwald

Deutschland

Tel +49(0)21 95 - 602-0
Fax +49(0)21 95 - 602-399

www.gira.de
info@gira.de