

4-channel universal dimming actuator 210W

Order no.: 1043 00

System information

This device is a product of the Instabus KNX/EIB-system and complies with KNX directives. Technical knowledge obtained in KNX training courses is a prerequisite to proper understanding.

The functionality of this device depends on the software.

Detailed information on loadable software and attainable functionality as well as the software itself can be obtained from the manufacturer's product database.

Planning, installation and commissioning of the unit is effected by means of KNX-certified software. The full functionality with KNX commissioning software from version ETS3.0d onwards.

The product database, technical descriptions and conversion programs and other utilities are available in the Internet at www.gira.de.



Safety instructions

Electrical equipment must be installed and fitted by qualified electricians only. Observe the current accident prevention regulations.

Failure to observe the instructions may cause damage to the device and result in fire or other hazards.

The device is not suited for safe disconnection of the mains supply.

Shutting off the device does not separate the load electrically from the supply.

Before working on the device or before replacing the lamp, disconnect the supply voltage (by cutting out the circuit breaker) to avoid the risk of an electric shock.

Disconnect the mains supply also when the connected load is changed (e.g. when another lighting fixture is installed).

If inductive transformers are used, each transformer must be fuse-protected on the primary side in accordance with the manufacturer's instructions.

Use only safety transformers in acc. with EN 61558-2-6.

These operating instructions are part of the product and must be left with the final customer.

Device components

Overview (Fig. 1)

- (1) keys for manual control
- (2) programming key and LED
- (3) Instabus KNX/EIB bus connection
- (4) mains supply connection
- (5) output status LEDs
- (6) Connection of outputs

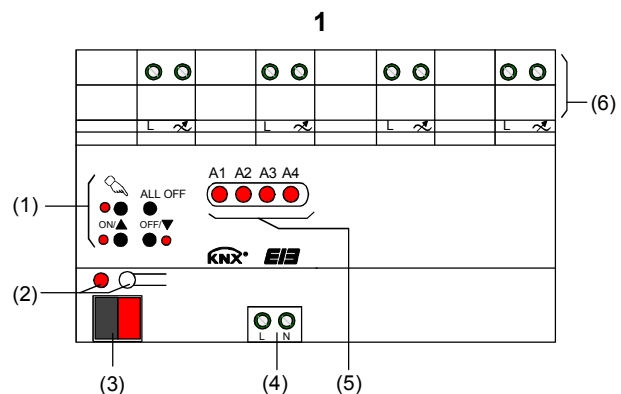

Function

Designated use

- Switching and dimming of 230 V incandescent lamps, 230 V halogen lamps and LV halogen lamps with inductive transformers or with TRONIC transformers.
- Installation on DIN rail in small distribution boards.

Product features

- Automatic or manual selection of the dimming principle compatible with the load type:

230 V incandescent lamps	resistive load	phase cut-off
230 V halogen lamps	resistive load	phase cut-off
LV halogen lamps with inductive transf.	inductive	phase cut-on
LV halogen lamps with TRONIC transf.	capacitive	phase cut-off

- Protected against no-load, short-circuit and over-temperature conditions
- Manual output control
- Checkback of switching status and dimming value
- Switch-on and dimming behaviour parametrizable
- Time dimmer, ON-delay, OFF-delay, staircase lighting timer
- Light-scene operation
- Disabling of individual outputs by hand or via the bus
- Output status indicated by LEDs
- Short-circuit warning
- Operating hours counter
- Dimming actuator shuts off after mains failures lasting longer than 5 s. Depending on parametrization, the device auto-detects the load after return of the mains voltage.
- Telecontrol signals from power supply companies may cause flickering of the lamps. This is not a defect of the product.



Delivery state: Provisional operation, output control with front panel keys possible.

Operation

Controls:

- (5) Output status LEDs
- (7) Key manual control
- (8) LED on: permanent manual control mode
- (9) Key **ON/▲** Switching on or increasing brightness
- (10) LED **ON/▲** on: selected output on, 1...100 %
- (11) Key **OFF/▼** Switching off / reducing brightness
- (12) LED **OFF/▼** on: selected output off
- (13) Key **ALL OFF** all outputs off

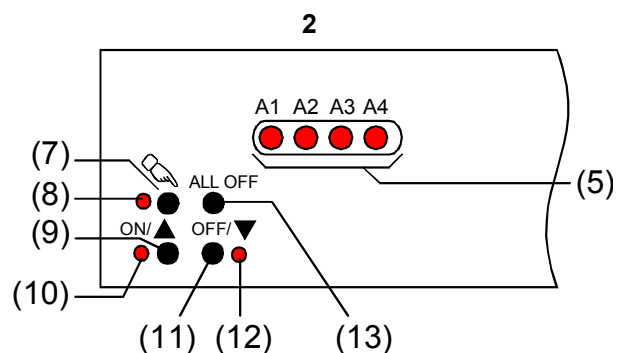

Status indication

The status LEDs **A1...A4** (Fig. 2, 5) indicate the output states.

- off: output is off
- on: output is on, brightness 1...100 %
- flashing slowly: output in manual control mode
- flashing fast: output disabled in permanent manual control mode

Modes of operation

- Bus operation: operation from touch sensors or other bus devices
- Temporary manual control mode: manual operation locally with keypad, automatic return to bus operation
- Permanent manual operation: only manual operation locally on device



Bus operation in manual mode disabled. Manual operation in the event of bus failure enabled. After failure and return of bus voltage, the device switches over to the bus mode. After failure and return of mains voltage, the device switches over to the bus mode. Manual control mode can be disabled in operation via bus telegram.

Activating the temporary manual control mode

Keypad operation is programmed and not disabled.

- Press the key briefly < 1 s. LED **A1** flashes, LED stays off.



After 5 s without key-press, the actuator returns automatically to the bus mode.

Deactivating the temporary manual control mode

The device is in the temporary manual control mode.

- No key-press for 5 s
or
- Press the key briefly < 1 s several times until the actuator quits the temporary manual mode. LEDs **A1...A4** indicate the status.

Activating the permanent manual control mode

Keypad operation is programmed and not disabled.

- Press the key for at least 5 s. LED is on, LED **A1** flashes, permanent manual control mode is activated.

Deactivating the permanent manual control mode

The device is in the permanent manual control mode.

- Press the key for at least 5 s. LED is off, bus operation is activated.

Switching the outputs

The device is in the permanent or temporary manual control mode.

- Press the key briefly < 1 s several times until the desired output is selected. The LED of the selected output **A1...A4** flashes. The LEDs **ON/▲** and **OFF/▼** indicate the status.
- Switch the output with the **ON/▲** or **OFF/▼** key.
Brief press: switching on / off
Long press: increase / reduce brightness
Release key: stop dimming



Temporary manual control mode: After all outputs have been selected one after another, the device quits the manual control mode with the next brief press.

Shutting off all outputs

The device is in the permanent manual control mode.

- Press the **ALL OFF** key. All outputs are shut off.

Disabling bus operation for individual outputs

The device is in the permanent manual control mode.

- Press the  key briefly < 1 s several times until the desired output is selected.
The status LED of the selected output **A1...A4** flashes.
The LEDs **ON/▲** and **OFF/▼** indicate the status.
- Press the keys **ON/▲** and **OFF/▼** simultaneously for at least 5 s.
The selected output **A1...A4** is disabled.
The status LED of the selected output **A1...A4** flashes fast.
- Activate the bus mode (deactivate the permanent manual control mode).



A disabled output can only be operated in the manual control mode.
When a disabled output is selected in the manual control mode, the respective status LEDs flashes twice briefly at intervals.

Re-enabling disabled outputs for bus operation

The device is in the permanent manual control mode.

- Press the  key briefly < 1 s several times until the desired output is selected.
The status LEDs of the selected output **A1...A4** flashes twice briefly at intervals.
- Press the keys **ON/▲** and **OFF/▼** simultaneously for at least 5 s.
The selected output **A1...A4** is enabled.
The status LED of the selected output **A1...A4** flashes slowly.
- Activate the bus mode (deactivate the permanent manual control mode).

Information for qualified electricians



DANGER!

Electric shock in case of accidental contact with live parts. Electric shocks may be fatal.

Before working on the device, cut out the mains supply and cover up live parts in the surroundings.

Fitting and electrical connection

Fitting the device

Observe the admissible temperature range. Ensure sufficient cooling.

- Fit the device by snap-fastening on a mounting rail in acc. with EN 60715. The connecting terminals must be at the top.

Connecting the device

Observe the admissible loads.
Observe the Technical Operating Conditions of the power supply companies.
Do not exceed the permissible total load including transformer losses.

Operate inductive transformers with at least 85 % of their rated load.

When mixed loads are used with inductive transformers, the share of resistive loads must not exceed 50 %.

Troublefree operation is ensured only with Gira TRONIC transformers or with inductive iron-copper transformers.



Caution!

Risk of irreparable damage with mixed loads. Do not connect capacitive loads (e.g. electronic transformers) and inductive loads (e.g. conventional transformers) in common to the same dimming output.

- Connect the device as shown in the wiring example (Fig. 3).

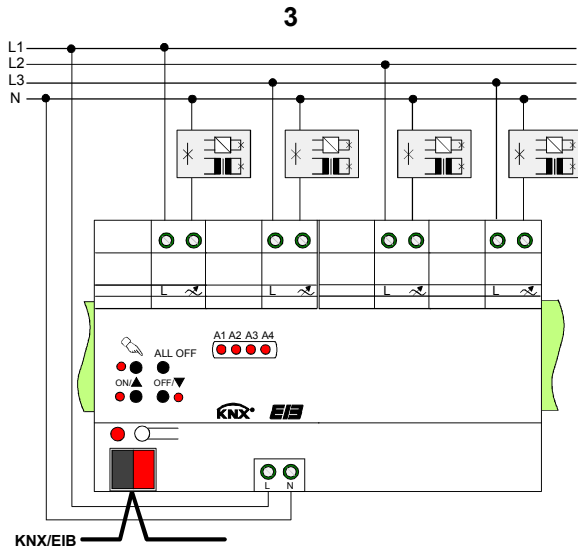

- Disconnect the load circuit.
- Disconnect the mains supply (Fig. 1, 4).
- Connect the new load.
- Recommission the device (see Commissioning).

Sliding on the cap

Protection of the bus lines against hazardous voltages, especially in the area of the terminals, by means of a cap.

The device is connected.

- Lead bus lines towards the rear of the device.
- Slide the cap over the bus terminal (Fig. 4, A) until it is heard to engage.

4A

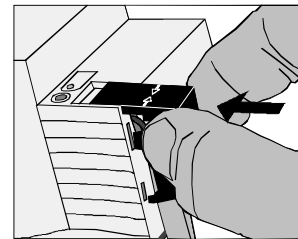

Delivery state: provisional operation possible, output control via keypad enabled. Automatic selection of dimming principle.

After reaching the total permissible load of the dimming actuator, the power can be increased with external boosters. The boosters must be selected to match the dimmers and the load. For more information see the instructions of the respective power booster.

Changing the type of load connected

Changing a connected load, e.g. by replacing a connected luminaire. The dimming actuator auto-detects the new load after disconnecting the power supply and the load.

Removing the cap

- Press the sides of cap and withdraw (Fig. 4, B).

4B

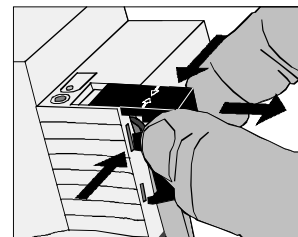

CAUTION!

Risk of irreparable damage if the preselected dimming principle and the connected load are not compatible.

Before changing the load, disconnect the mains supply and the load circuit concerned.

Check the parameter settings and correct, if needed.

Commissioning



CAUTION

Risk of irreparable damage if the preselected dimming principle and the connected load are not compatible.

Make sure before commissioning that the software settings are compatible with the load.

- Switch on the bus voltage.
- Allocate the physical address and load the application software into the device.
- Switch on the mains voltage at the outputs.
- Switch on the mains supply.
The device auto-detects the load and selects the appropriate dimming principle (phase cut-on or phase cut-off).



The detection phase is characterized by brief flickering of the lamp and lasts between 1 and 10 seconds depending on power supply conditions.

Control commands received during the adaptation procedure are executed on completion thereof.

The dimming principle can be predefined during parameterization of the device. In this case, the auto-detect procedure is omitted.

Technical data

KNX medium:	TP1
Mode of commissioning:	S-Mode (ETS)
Instabus KNX/EIB supply:	DC 21...32 V
Instabus KNX/EIB power consumption:	max. 150 mW
Mains voltage:	AC 190...230 V~ +10/-15 %
Mains frequency:	50/60 Hz
Total dissipated power:	max. 8.5 W (with max. load)



The symbols used to identify dimmer loads designate the type of the electrical behaviour of loads connected to dimmers: R = ohmic, L = inductive, C = capacitive

Connection

Instabus KNX/EIB:	connecting terminal
230 V supply and outputs:	Screw terminals
single-wire:	1.5...4 mm ² 2 x 1.5...2.5 mm ²
stranded wire without ferrule:	0.75...4 mm ²
stranded wire with ferrule:	0.5...2.5 mm ²
Load line length per output:	max. 100 m
Screw terminal tightening torque:	max. 0.8 Nm
max. housing temperature:	T _C = 75 °C
Ambient temperature:	-5...+45 °C
Storage temperature:	-25...+70 °C
Mounting width:	144 mm (8 modules)
Weight:	approx. 200 g

Connected load per output (Fig. 5)

AC 230/240 V ±10%:	20...210 W / VA
230 V halogen lamps:	20...210 W / VA
LV halogen lamps with TRONIC transformers:	20...210 W / VA
LV halogen lamps with inductive transformers:	20...210 W / VA
Mixed load resistive / inductive:	20...210 W / VA
Mixed load resistive / capacitive:	20...210 W / VA
Mixed load inductive / capacitive:	non-permissible

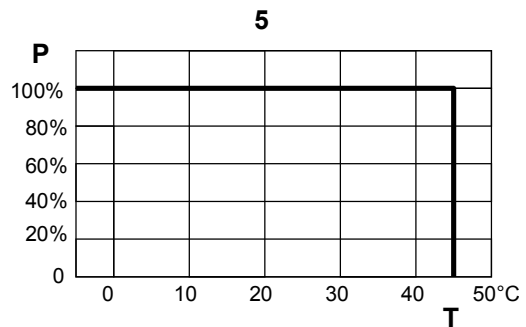

Troubleshooting

Output has shut off

Cause 1: Short-circuit in output circuit.
Disconnect the mains supply and the concerned output from the mains.
Remove the short-circuit.
Reconnect at first the output voltage and then the mains supply.
Switch the concerned output off and then on again.

i In case of a short-circuit during the auto-detect cycle, the load is relected automatically when the short-circuit has been removed.

In case of a short-circuit, the concerned output shuts off. Automatic restart after removal of the short-circuit within 100 ms (inductive load) and 7 s (capacitive or resistive load). Thereafter, permanent shut-off.

Cause 2: Output overheated, overtemperature protection activated
Wait unit device has cooled down.
For faster cooling shut off other outputs, if possible, ensure proper cooling.
If repeated: reduce the load.

i Shut-off of overheated outputs. Depending on programming, the output auto-detects the load after cooling and can be reactivated.

Cause 3: Load failure.
Check the load, replace the lamp, check the primary fuse with inductive transformers and replace, if necessary.

Manual control via keypad not possible

Cause 1: Manual control not programmed.
Reprogram the device.

Cause 2: Manual control mode disabled via the bus.
Enable the manual control mode.

Output control not possible

Cause: Output disabled.
Re-enable the output.

None of the outputs operational

Cause 1: All outputs disabled.
Re-enable the outputs.

Cause 2: Manual control active.
Deactivate the permanent manual control mode (switch this mode off).

Cause 3: Application software stopped, programming LED flashes.
Disconnect device from bus, reconnect after ca. 10 s.

Cause 4: No or faulty application software.
Check programming and rectify.

All outputs off, activation not possible

Cause 1: Bus voltage failure.
Check the bus voltage

Cause 2: Mains voltage failure.
Check the mains voltage at outputs and at the supply.

Lamps flickering or humming, proper dimming not possible, device humming

Cause: Incorrect dimming principle selected. Installation or commissioning fault. Disconnect the device and the luminaire from the power supply, cut out the circuit breaker. Check the installation and rectify. If the wrong dimming principle has been selected: Adjust the correct dimming principle. If the dimming actuator auto-detects the load wrongly, e.g. in case of strongly inductive network or long load lines. Preselect the correct dimming principle with the commissioning software.

Lamps flicker irregularly

Cause: Telecontrol pulses from power supply company.
Use audio frequency filters.

Accessories

'Universal' power booster REG: Order no. 1035 00
TRONIC built-in power booster: Order no. 0380 00
LV built-in power booster: Order no. 0364 00

Acceptance of guarantee

We accept the guarantee in accordance with the corresponding legal provisions.

Please return the unit postage paid to our central service department giving a brief description of the fault:

Gira
Giersiepen GmbH & Co. KG
Service Center
Dahlienstrasse 12
D-42477 Radevormwald

Gira
Giersiepen GmbH & Co. KG
Postfach 1220
D-42461 Radevormwald

Telefon: +49 / 21 95 / 602 - 0
Telefax: +49 / 21 95 / 602 - 339
Internet: www.gira.de