

Radio Control Central Unit
0358 18

GIRA



Controls and connectors

- (1) Display with 7 lines
- (2) 4 function keys (soft-keys)
- (3) 12 keys (keypad)
- (4) Chip-card reader
- (5) Main connection
- (6) Interface (Western socket)
- (7) Digital input
- (8) Temperature sensor
- (9) Master key

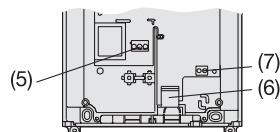
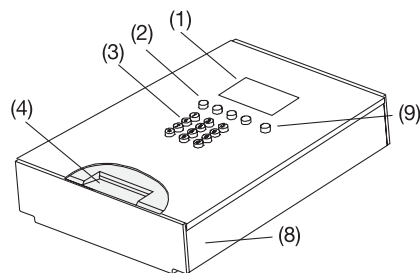

Standard display

- (10) Time of day
- (11) Weekday
- (12) DCF77 field-strength indicator
- (13) DCF77 receive indicator
- (14) Keypad lock
- (15) Short-message symbol
- (16) Presence / absence symbol
- (17) Function key menu line
- (18) Temperature indication
- (19) Transmit / receive indicator
- (20) Power supply
- (21) Battery indicator

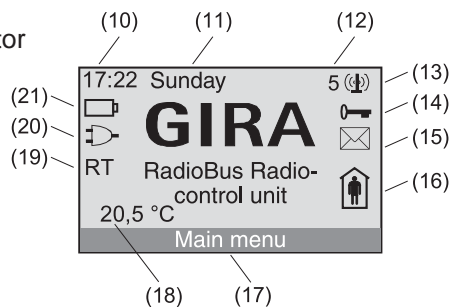

Introduction

Overview

With the radio control central unit you have decided in favour of a modern radio control central unit which gives you all the comfort and security needed in your environment.

The radio control unit enlarges your radio control installation by time-controlled and automated lighting and shutter operation functions. Controlled by programs of own, it can switch the lighting and move the shutters for you during your absence (presence simulation). The astro function gives you the possibility to execute switching commands depending on sunrise and sunset times. Moreover, all radio control devices can still be operated in the usual way without the radio control unit.

You can store and recall light-scenes, set up time-dependent logic links involving several radio control transmitters and store a short message.

With chip-cards, you can save your own settings and program new functions into the device.

To make use of all the advantages offered by the system, read this manual carefully. It contains useful information and suggestions ensuring faultless operation of the system.

System information

The radio control unit is compatible with all transmitters and receivers of the RadioBus System, except for the radio control power amplifier (order no. 0843 02).

The radio control unit is furthermore not compatible with the following systems or units:

- DALI System
- Instabus radio control converter (order no. 0868 00)

About this manual

This manual is composed of 3 parts:

- 1.) The **Fitting and initial start-up instructions** are intended for the electrical fitter with important information for optimal installation and programming of the radio control unit.
- 2.) The **Operating instructions** are intended in first place for the customer and contain a step-by-step introduction into the operation of the unit and are also of help in answering more detailed questions.
- 3.) The **Annex** contains information about the technical characteristics, troubleshooting procedures and product warranty.

Symbols used



Warnings against risks of injury and life-threatening hazards



Technical information and recommendations for a better understanding of the device and its functions.



Page reference to more detailed information in this manual.

Manual

Fitting and initial start-up
(for the electrical fitter)

Table of contents

Fitting and initial start-up

1.0	Fitting and initial start-up	10
1.1	Scope of supply	10
1.2	Selecting the fitting location	10
1.2.1	Information on radio equipment operation	11
1.2.2	Radio transmission	12
1.3	Fitting	13
1.4	Removal of the front cover	17
1.5	Inserting or replacing the batteries	18
2.0	Initial start-up	20
2.1	Setting the time	22
2.2	Integrating an external repeater	24
2.3	Programming of radio control receivers	26
2.4	Programming of radio control transmitters	32
2.5	Setting up time-controlled programs	38
2.6	Setting up logic links	51

3.0	List of components	65
3.1	Changing the name of a room	66
3.2	Changing of transmitters and receivers	67
3.3	Programming new transmitters or receivers in existing rooms	71
3.4	Special functions (delay, action)	73
4.0	Repeater functions	77
4.1	Using an external repeater	78
4.2	Using the internal repeater	79
5.0	Radio control unit capacity utilization	82

GIRA
RadioBus system

1.0 Fitting and initial start-up

Safety warning



Attention!
Electrical appliances must be fitted and installed by qualified electricians only.

1.1 Scope of supply

The scope of supply of the radio control unit includes:

- 1 radio control unit
- 1 mains connection cord
- 1 drill template
- 1 fitting set with 3 screws and plugs
- 1 manual with 1 radio control unit Mastercard

To ensure operation of the radio control unit in the event of mains failures, the device must be equipped in addition with 5 Micro batteries (type: AAA 1.5 V LR 03). The batteries also facilitate the programming procedures for transmitters and receivers.

1.2 Selecting the fitting location

For optimal viewing of the radio control unit display, it is recommended to install the device at the customer's eye level.

As the transfer of information between the radio control unit and the programmed transmitters and receivers is ensured by radio waves, the following points should be observed when selecting the fitting location:

- In order to protect the radio transmission against interference from other electrical appliances, the device should be installed at an approximate distance of 0.5 m from other electrical consumers (e.g. microwave oven, HiFi and TV equipment).
- To ensure optimal radio transmission, the fitting location should also be at a sufficient distance from large metal pieces (e.g. metallic door frames or cupboards).
- Select an easily accessible, central location inside your radio control system and make sure that all components of the radio system can be safely reached. Observe also the instructions set out in chapters 1.2.1 and 1.2.2.

1.2.1 Information on the operation of radio equipment

- The inter-connection of this radio system with other communication networks must comply with national legislation.
- This radio system must not be used for communication beyond property boundaries.
- Operation in Germany is subject to the relevant regulations of Amtsblatt Vfg 73/2000.
- If utilized in conformity with its designated use, this unit fulfills the requirements of the R&TTE Directive (1999/5/EG). The complete declaration of conformity can be found in the Internet under: www.gira.de/konformitaet

The radio control unit may be operated in all countries of the EU and the EFTA.

1.2.2 Radio transmission

Radio transmission takes place on non-exclusive frequencies. Interference can therefore not be excluded. This type of radio transmission is not suitable for safety applications such as emergency shut-off or emergency calling functions.

The range of a radio system depends on transmitter output power, receiver characteristics, humidity of the air, installation height and on local building conditions. Some examples for radio wave penetration in building materials:

Material	Penetration
Timber, gypsum, gypsum plaster-boards	approx. 90 %
Brickwork, press-boards	approx. 70 %
Reinforced concrete	approx. 30 %
Metal, metal grating, aluminium	approx. 10 %
Rain, snow	approx 0-40 %

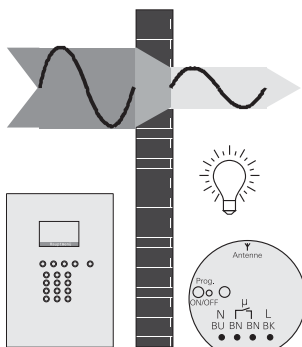

Fig. 1.a: Material penetration

1.3 Fitting

Safety warnings



Attention

Electrical appliances must be installed and fitted only by qualified electricians.



Important

- Before fitting the radio control unit it is recommended to program the radio control transmitters and receivers already existing into your radio control unit beforehand. Read the information in chapter 2.0 "Initial start-up".
- When selecting a suitable location for the unit, observe also the information provided in chapter 2.1 "Setting the time" in order to ensure optimal reception of the DCF77 time standard signals.
- For easy reading of the display, the radio control unit should not be installed in direct sunlight.

The radio control unit can be installed as stand-alone unit, but can also be integrated into the modular function console. For installing individual units on the surface, a fitting frame is required.

1.3 Fitting

1. Select the optimal fitting location.
Select the installation height so that the display can be easily read. The recommended installation height is approx. 1.40 m.
2. Attach the fitting section or the fitting frame to the wall (see fitting instructions for function console or fitting frame).
3. Open the radio control unit.
4. Detach the rear wall of the housing from the front withdrawing the ribbon cable ① from the front.
5. Open the required cable inlets in the housing of the radio control unit and lead the connecting cables into the box.
Important: Recommended line for efficient strain relief H 03 VV-F 2x0.75
6. Place the box into the fitting section or fitting frame and fasten with the retaining screws.

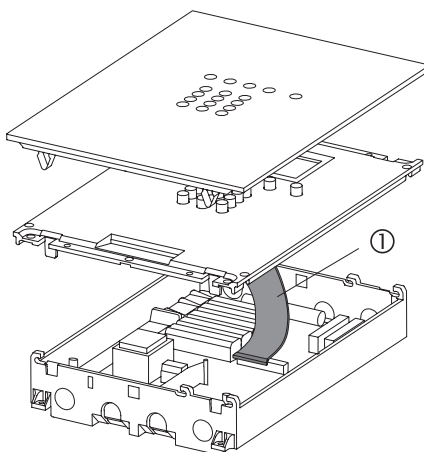

Fig. 1.b: Opening the radio control unit housing

1.3 Fitting

7. Remove the terminal box ① by loosening screw ②.
8. Remove the insulation of the connecting cables.
9. Open the strain-relief clamp ③.
10. Lead the cable through the inlet into the housing ④ and connect to terminal ⑤.
11. Close the strain-relief clamp and screw the terminal box back in place.
Important: Make sure the cable jacket reaches into the terminal box ①.
12. Replug the ribbon cable into the connector in the front part of the housing.
Make sure the connector is plugged in properly.
13. Put the base-plate on the housing and fasten it with the four screws to the fitting section or the fitting frame.
14. Install the glass cover and press until the retaining clips engage.

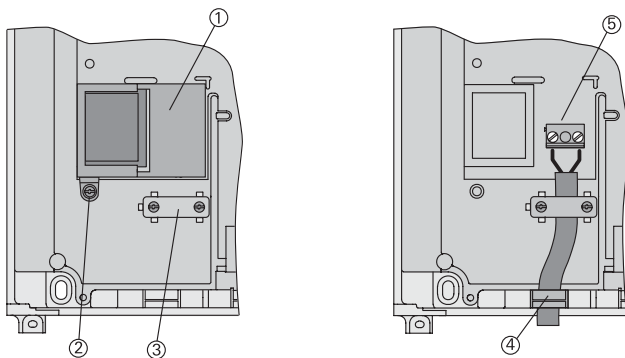

Fig. 1.c: Connection of mains supply line

1.4 Removal of the front cover

To remove, withdraw the glass front cover forwards using both hands (see illustration).

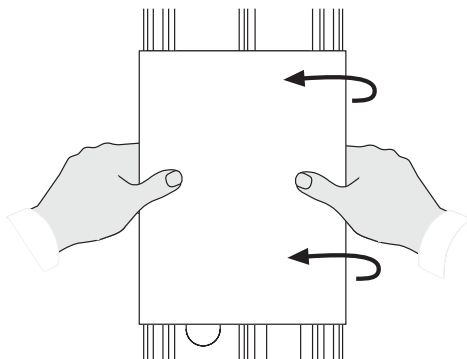

Fig. 1.d: Removal of the glass front

1.5 Inserting or replacing the batteries

To ensure operation of the radio control unit in the event of mains failures, the device must be equipped with 5 Micro cell batteries (type: AAA 1.5 V LR 03). The batteries also facilitate the programming procedures for transmitters and receivers.

The battery charge is indicated by the battery symbol (21) on the standard display. More information on this subject can be found in chapter 1.2 "The standard display".



Safety warnings and disposal instructions

Attention: Batteries must not get into the hands of children. Remove used batteries immediately and discard without polluting the environment. Replace batteries only by batteries of the same type.

After opening of the radio control unit there is a risk of accidental contact with exposed live wires and of electric shocks. Therefore, pull the mains cord of the unit out of the socket or cut out the respective circuit breaker.

General information



- Do not use rechargeable batteries. They have a lower capacity than primary batteries.
- During normal operation of the radio control unit with mains voltage, no power is drained from the batteries.
- With new batteries, the radio control unit can be supplied with power in the event of mains failures for about 6 hours.

1.5 Inserting or replacing the batteries

To insert the batteries, proceed as follows:

1. Pull the plug out of the socket or cut out the respective circuit breaker.
2. Withdraw the glass cover (cf. chapter 1.4).
3. Remove the four screws from the baseplate.
4. Detach the rear of the housing from the front and withdraw the ribbon cable from the front (cf. chapter 1.3).
5. Insert the batteries. Pay attention to correct polarity as shown in fig. 1.e.

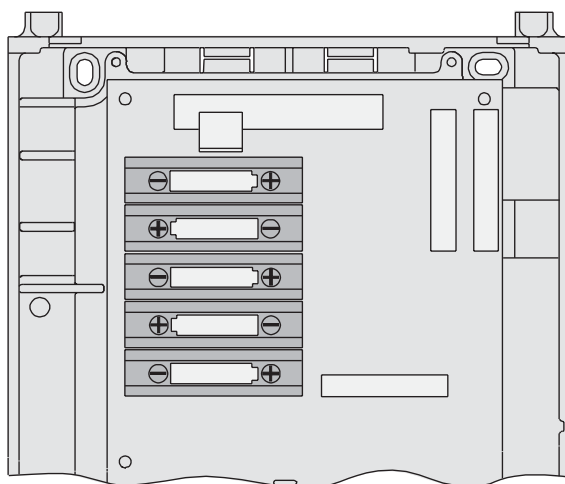

Fig. 1.e: Battery compartment inside the radio control unit

2.0 Initial start-up



At first please make yourself familiar with the use of the radio control unit menu. Detailed instructions are set out in chapter 1.0 "Introduction" of the manual and especially in 1.3 "Directions for use".



It is recommended to operate the radio control unit during initial start-up with batteries as the radio control unit must be operated for programming purposes within a radius of 5 m from your radio control appliances. Do not forget that for energy saving purposes the display backlighting is always off during battery operation.

To facilitate the initial start-up, you will be guided automatically through the first steps by an initial start-up assistant after connecting the power supply (batteries or mains). The assistant will guide you through the following start-up dialogs:

1. Setting the time (chapter 2.1)
2. Integrating an external repeater (chapter 2.2)
3. Programming of radio control receivers (chapter 2.3)
4. Programming of radio control transmitters (chapter 2.4)
5. Setting up time-controlled programs (chapter 2.5)
6. Setting up logic links (chapter 2.6)

If you have already stored data in the radio control unit, the initial start-up assistant is not started automatically. It can nevertheless be used for further entries and can be activated in the radio control unit menu under "*Configuration – Initial start-up*". The initial start-up will then begin with screen 2.0.2.

2.0 Initial start-up

For initial start-up, please follow the instructions of the initial start-up assistant on the display of the radio control unit:

2.0.1

Confirm the opening screen with "Next"

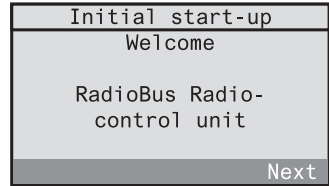

2.0.2

Confirm the following info screen with "Next".
"Abort" returns to the main menu.

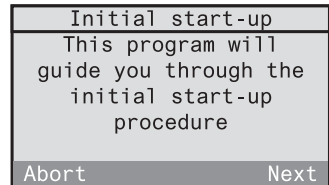

2.0.3

To enter into the start-up dialog "Setting the time", press "Yes". Continue with chapter 2.1.
"No" takes you to the next start-up dialog (in this case: "Repeater").

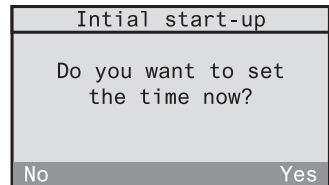

2.1 Setting the time

The radio control unit is equipped with a DCF77 radio receiver. Within a radius of about 1500 km from the time signal transmitter (DCF77) in Frankfurt, Germany, the date and time display can be synchronized with the signal from this station. The advantage of using the DCF77 time signal is that the time of day is always correct without any manual correction being needed.

To determine the field strength of the DCF77 signal when setting the time, the radio control unit is equipped with a field strength indicator (cf. fold-out page (12)).

The quality of the DCF77 signal received is indicated by the field strength indicator as a figure between 0 and 5:

- 0, 1, 2: DCF77 reception is insufficient.
- 3: DCF77 can be received only with restrictions.
- 4: DCF77 reception is good.
- 5: DCF77 reception is very good.

The first synchronizing procedure may last between 2 and 15 minutes. When the clock is synchronized, the field strength indicator is no longer displayed.

If the reception of the DCF77 time signal is not possible, the time must be set by hand. In this case, the clock runs with quartz precision.

The setting of date and time can be effected with the help of the start-up dialog "Setting the time" which is part of the initial start-up assistant.

To set the time and date after initial start-up, the start-up dialog "Setting the time" can also be called up directly in the main menu under "*Configuration - System - Setting the time*".

To set the time, follow the dialog instructions on the display of the radio control unit.

2.1 Setting the time

2.1.1

When DCF reception is possible, select here "DCF on" (continue with 2.2.1) otherwise select "DCF off" (continue with 2.1.2).

"Back" returns to the previous screen.

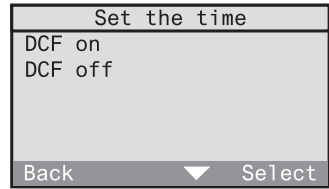

2.1.2

If "DCF off" is selected, the date must be set here. The weekday is set automatically. Set the date directly with the numerical keys. With "▲" and "▼" the date can be changed by the day either slowly (brief press) or fast (long press).

Confirm your selection with "Ok".

"Back" returns to the previous screen.

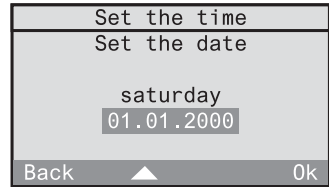

2.1.3

Set the time directly using the numerical keys. With "▲" and "▼" the time can be changed by the minute either slowly (brief press) or fast (long press).

Conform your selection with "Ok".

"Back" returns to the previous screen.

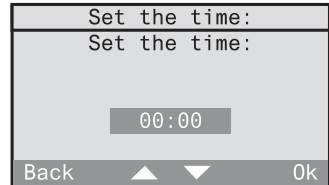

If the start-up dialog "Setting the time" had been called up directly from within the menu, "Ok" will take you back to the menu.

If you are within the initial start-up, "Ok" continues with the integration of an external repeater. Continue with chapter 2.2.

2.2 Integrating an external repeater

With an external repeater, the transmitting range and thus the working radius of a radio control system can be enlarged.

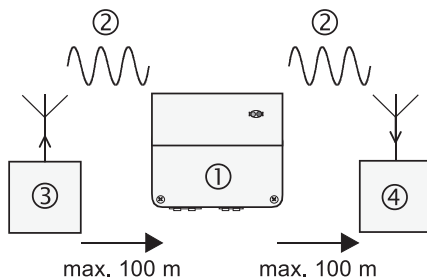

Fig. 2.a: Functioning of a repeater

The repeater ② receives radio telegrams ② from radio transmitters ③ and retransmits them after a check with maximum power. The telegram is received and evaluated by a radio receiver ④.

An external radio repeater and also a radio control unit use the pauses between telegrams to send telegrams of their own.

To avoid telegram collisions, any external repeater must be integrated into the radio control unit.

Radio transmission between transmitters and receivers can thus be optimized.

All radio telegrams passing via the radio control unit (e.g. for logic links) will only be transmitted after they have been received as a whole. This causes time delays between the actuation of a transmitter and the actual execution of the command.

With normal short actuations of a transmitter, the delay is approximately 1 second. For long actuations which are needed, for instance, to move a shutter into its limit position, the command is executed only after the transmitter has transmitted all telegrams.

2.2 Integrating an external repeater

2.2.1

Confirm the info text with "Next".
"Abort" returns to the main menu.

Initial start-up	
If a repeater is installed, it should be registered now.	
Abort	Select

2.2.2

If you do not use a repeater in your radio control system, select "No", or otherwise "Yes".

External repeater	
Do you use an external repeater?	
Yes	
No	
Back	Select

An external repeater can also be integrated later into the radio control unit. To do so, select "*Configuration - System - Repeater*" in the menu. Moreover, the radio control unit itself can also be used as a repeater. Read chapter 4 of the fitting and start-up instructions.

In the initial start-up, the next dialog is the start-up dialog "*new receiver*" (screen 2.2.3).

2.2.3

To launch the start-up dialog "*new receiver*", press "Yes". Continue reading in chapter 2.3. "No" takes you to the next start-up dialog (here: "*new receiver*").

Initial start-up	
Do you want to program new receivers now?	
No	Yes

2.3 Programming of radio control receivers

In order to integrate your existing radio control unit (e.g. switching, dimming and shutter actuators) into time-controlled programs of the radio control unit, the radio control unit must be programmed into these radio control receivers.

This is done with the start-up dialog *"new receiver"* which is part of the initial start-up assistant.

For adding further radio control receivers after initial start-up, the *"new receiver"* start-up dialog can also be called up directly from the main menu under *"Configuration – Components – New receiver"*.



Since the radio control unit and the radio control receiver must not be farther apart than 5 m from each other for programming, it is recommended to operate the radio control unit with batteries. Do not forget that for energy saving purposes the display backlighting is always off during battery operation.

To program radio control receivers, follow the dialog instructions on the display of the radio control unit.

2.3 Programming of radio control receivers

2.3.1

Confirm the info text for receiver programming with "Next".

"Abort" returns to the main menu.

New receiver	
A new receiver can now be named and assigned to a room.	
Abort	Next

2.3.2

Select at first a room for the receiver. Then confirm the info text with "Next".

"Abort" returns to the main menu.

New receiver	
Select first a room.	
Abort	Next

2.3.3

Select a room from the room list (continue with 2.3.7) or add a new room. To add a new room, select <new room > (continue with 2.3.4).

"Back" returns to the previous screen.

Room	
<new room>	
Back	Select

2.3.4

If you have selected <new room >, you can give the room a name.

Confirm the info text with "Next".

"Back" returns to the previous screen.

New room	
Select a name for the room.	
Back	Next

2.3.5

Select a room name from the list or select <new name> in order to add a new room name. Confirm your selection with "Select".

"Back" returns to the previous screen.

New room	
<new name>	
No room	
Living room	
Kitchen	
Bathroom	
Back	▲ ▼ Select

2.3 Programming of radio control receivers

2.3.6

In this screen, the selected room name can be edited or the new room name entered. The name may consist of up to 16 characters. For entering text, use the keypad (see fold-out page (3)).

"*Abc*" shifts between capital and small letters.

"<-" deletes the last character.

When you have entered a room name, confirm with "*Ok*".

"*Back*" returns to the previous screen.

New room		
Confirm your selection or enter a new name.		
<hr/>		
Back	<- Abc	Ok

2.3.7

Confirm the info text with "*Next*".

"*Back*" returns to the previous screen.

New receiver	
Select the type of the receiver.	
Back	Next

2.3.8

Select the type of your radio control receiver from the following list. Confirm with "*Select*".

The receivers above the broken line are receiver types that have already been programmed (here: none).

"*Back*" returns to the previous screen.

Receiver types	

Dimming actuator	
Switching actuator	
Push-button actuator	
Shutter actuator	
Back	▼ Select

2.3.9

In the example above, a dimming actuator was selected. Confirm the following info screen with "*Next*".

"*Back*" returns to the previous screen.

New receiver	
Please select a name for the receiver.	
Back	Next

2.3 Programming of radio control receivers

2.3.10

Now select a name for your radio control receiver (here: dimming actuator) from the list or select *<new name>* to enter a new name.

Confirm your selection with "Select".

"Back" returns to the previous screen.

Dimming actuator	
<new name>	
Ceiling lamp	
Wall luminaire	
Standard lamp	
Reading lamp	
Back	Select

2.3.11

In the following screen, the selected name can be edited or the new name entered. The name may consist of up to 16 characters.

For entering text, use the keypad (see fold-out page (3)).

"Abc" shifts between capital and small letters.

"<" deletes the last character.

When you have entered a room name, confirm with "Ok".

"Back" returns to the previous screen.

Dimming actuator	
Confirm your selection or enter a name.	

Back	<- Abc Ok

The actual programming procedure can now be started. The programmed identification is stored only in the receiver. Information about how to operate the selected receiver for programming can be found in the corresponding receiver operating instructions.

During the programming cycle, the sensitivity of the radio control receivers is reduced to about 5 m. The distance between the radio control receiver and the radio control unit to be programmed into the receiver should therefore be between 0.5 m and 5 m.

2.3 Programming of radio control receivers

2.3.12

Bring the radio control unit to within a radius of 5 m from your radio control receiver and switch the receiver into the programming mode (see radio receiver operating instructions).

Confirm with *"Next"*. The radio control unit starts sending programming telegrams.

"Back" returns to the previous screen.

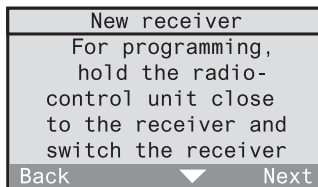

2.3.13

Check whether the radio control receiver has confirmed the programming procedure (see radio receiver operating instructions). In the absence of a confirmation, the programming cycle can be repeated from step 2.3.12 onwards by pressing *"No"*.

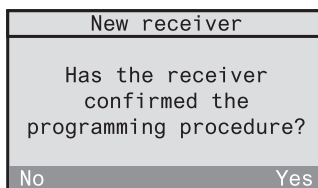

2.3.14

Quit the receiver programming mode. (see radio receiver operating instructions) and then confirm with *"OK"*.

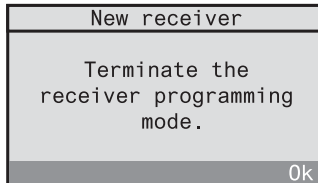

2.3.15

The programming procedure for this radio control receiver is now terminated. If you want to program another receiver, press *"Yes"* and the programming procedure begins again with step 2.3.2.

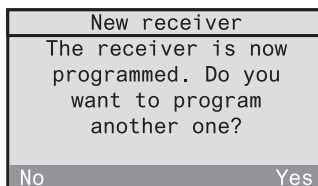

2.3 Programming of radio control receivers

If you have called up the "new receiver" start-up dialog directly from within the menu, pressing "No" takes you back to the menu.

If you are within the initial start-up, pressing "No" now launches the "new transmitter" start-up dialog (step 2.3.16).

2.3.16

To launch the "new transmitter" start-up dialog, press "Yes". Continue reading in chapter 2.4.

"No" takes you to the next start-up dialog (here: "new program").

Initial start-up	
Do you want to program new transmitters now?	
No	Yes



To change or to delete a programmed radio control receiver, read chapter 3.2 "Changing transmitters and receivers" of the present fitting and start-up instructions.

2.4 Programming of radio control transmitters

All radio control transmitters (e.g. hand-held or wall-mounted transmitters) to which functions are assigned via logic linking in the radio control unit, must be programmed into the radio control unit.

This is done with the start-up dialog "*new transmitter*" which is part of the initial start-up assistant.

For adding further radio control transmitters after initial start-up, the "*new transmitter*" start-up dialog can also be called up directly from the main menu under "*Configuration – Components – New transmitter*".



Since the radio control unit and the radio control transmitter must not be farther apart than 5 m from each other for programming, it is recommended to operate the radio control unit with batteries. Do not forget that for energy saving purposes the display backlighting is always off during battery operation.

To program radio control transmitters, follow the dialog instructions on the display of the radio control unit.

2.4 Programming of radio control transmitters

2.4.1

Confirm the info text for programming of radio control transmitters with "Next".

"Abort" returns to the main menu.

New transmitter	
A new transmitter can now be named and assigned to a room.	
Abort	Next

2.4.2

Select at first a room for the transmitter.

Then confirm the info text with "Next".

"Abort" returns to the main menu.

New transmitter	
Select first a room.	
Abort	Next

2.4.3

Select an existing room from the room list (e.g. living room in this case) (continue with 2.4.7) or add a new room. To add a new room, select <New room > (continue with 2.4.4).

"Back" returns to the previous screen.

Room	
<new room> Living room	
Back	Select

2.4.4

If you have selected <new room >, you can give the room a name.

Confirm the info text with "Next".

"Back" returns to the previous screen.

New room	
Select a name for the room.	
Back	Next

2.4.5

Select a room name from the list or select <new name> in order to add a new room name.

Confirm your selection with "Select".

"Back" returns to the previous screen.

New room	
<new name> No room Living room Kitchen Bathroom	
Back	Select

2.4 Programming of radio control transmitters

2.4.6

In this screen, the selected room name can be edited or the new room name entered. The name may consist of up to 16 characters. For entering text, use the keypad (see fold-out page (3)).

"*Abc*" shifts between capital and small letters.
"←" deletes the last character. When you have entered a room name, confirm with "*Ok*".

"*Back*" returns to the previous screen.

New room		
Confirm your selection or enter a name.		

Back	←- Abc	Ok

2.4.7

Confirm the info text with "*Next*".

"*Back*" returns to the previous screen.

New transmitter	
Select the transmitter type.	
Back	Next

2.4.8

Select the type of your radio control transmitter from the following list.

Confirm with "*Next*".

The transmitters above the broken line are transmitter types that have already been programmed (here: none).

"*Back*" returns to the previous screen.

Transmitter types		

Mini transmitter		
Hand transmitter		
Wall transmitter		
MF transmitter		
Back	▲ ▼	Select

2.4.9

In the example above, a hand-held transmitter was selected.

Confirm the following info screen with "*Next*".

"*Back*" returns to the previous screen.

New transmitter	
Select a name for the transmitter.	

Back	Next

2.4 Programming of radio control transmitters

2.4.10

Now select a name for your radio control transmitter (here: hand-held transmitter) from the list or select *<New name>* to define a new name.

Confirm your selection with "Select".

Hand transmitter	
<new name>	
Hand transmitter	
Back	Select

2.4.11

In the following screen, the selected name can be edited or the new name entered. The name may consist of up to 16 characters.

For entering text, use the keypad (see fold-out page (3)).

"*Abc*" shifts between capital and small letters.

"<" deletes the last character. When you have entered a room name, confirm with "Ok".

"Back" returns to the previous screen.

Hand transmitter	
Confirm your selection or enter a new name.	

Back	Ok

The actual programming procedure can now be started. The programmed identification is stored only in the receiver.



To change or to delete a programmed radio control receiver, read chapter 3.2 "Changing transmitters and receivers" of the present fitting and start-up instructions.

2.4 Programming of radio control transmitters

2.4.12

During programming of a radio control transmitter, the sensitivity of the radio control unit is reduced to about 5 m. The distance between the radio control transmitter and the radio control unit should therefore be between 0.5 m and 5 m. "Back" returns to the previous screen.

New transmitter	
For programming, hold the radio-control unit close to the transmitter.	
Back	Next

2.4.13

Start sending a programming telegram from your transmitter (see radio control transmitter operating instructions). If the radio control transmitter is identified, the radio control unit automatically changes over to the next screen (2.4.14). If the transmitter was already programmed before, the radio control unit remains in this screen.

Hand transmitter	
Start sending a programming telegram with the transmitter.	
Back	

2.4.14

"Yes" adds the identified transmitter to the list of transmitters. "No" rejects the identified transmitter and takes you back to step 2.4.12.

Hand transmitter	
A transmitter has been detected. Do you want to add this transmitter?	
No	Yes

2.4.15

The transmitter is now programmed in the radio control unit. If you want to program another radio control transmitter, press "Yes" and the programming procedure for a new transmitter begins again with step 2.4.2.

New transmitter	
The transmitter is programmed. Do you want to program another transmitter?	
No	Yes

2.4 Programming of radio control transmitters

If you have called up the "new transmitter" start-up dialog directly from within the menu, pressing "No" takes you back to the menu.

If you are within the initial start-up, pressing "No" launches the "New program" start-up dialog (step 2.4.16).

2.4.16

To launch the start-up dialog "new program", press "Yes". Continue reading in chapter 2.5. "No" displays the next start-up dialog (here: "New logic link").

Initial start-up	
Do you want to set up programs now?	
No	Yes

2.5 Setting up time-controlled programs

Programs can be used to assign tasks consisting of certain actions to be performed at specified times to your previously programmed radio control receivers.

Programs are set up with the help of the start-up dialog "new program" which is part of the initial start-up assistant.

For setting up new programs after initial start-up, the start-up dialog "new program" can also be called up directly from the main menu under "*Configuration – Programs – <New program>*".

To set up time-controlled programs, follow the dialog instructions on the display of the radio control unit.

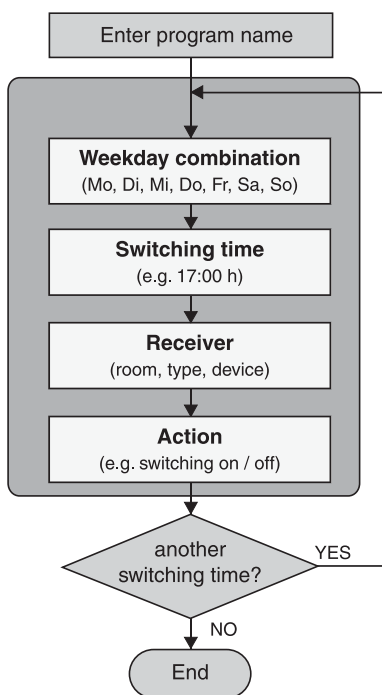
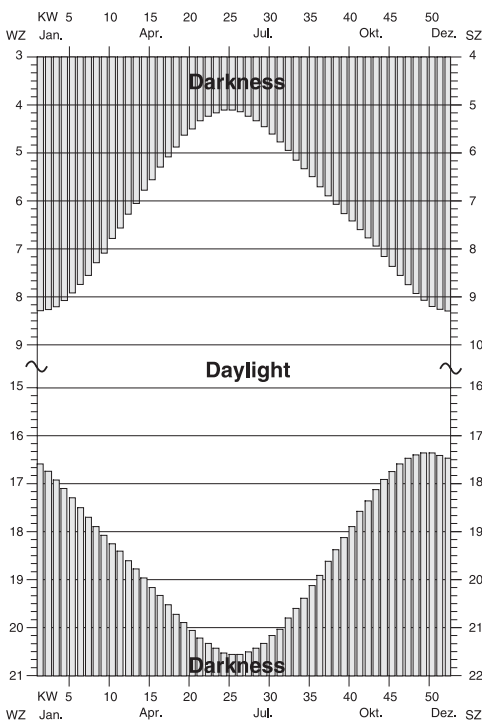

Fig. 2.b:
Program entry sequence

Astro time

The switching times stored in your programs can – if necessary – be automatically adapted to the astro time (sunset and/or sunrise times during the year). A distinction is made between switching times for blinds/shutters and lighting.



WZ: Central European winter time
 SZ: Central European summer time (winter + 1 h)

Fig. 2.c:
 Astro switching times over the year (approx. location: Würzburg)

When the astro function is active, the switching times will be shifted as follows:

Blind/shutter:

Switching times in the morning falling into darkness will be executed at the time of sunrise (astro morning curve).

Switching times in the evening falling into darkness will be executed at the time of sunset (astro evening curve).

2.5 Setting up time-controlled programs

Example for blinds/shutters:

MON - SUN: 06:30 h shutter raised

MON - SUN: 19:10 h shutter lowered

The shutter is raised in the morning at sunset – but not before 6:30 h – and is lowered in the evening at sunset – but not later than 19:10 h.

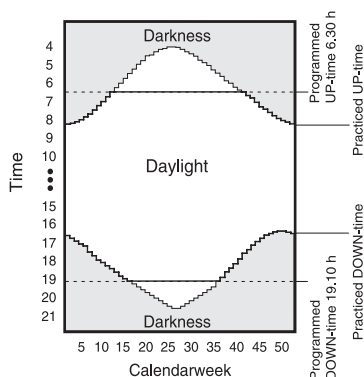

*Fig. 2.d:
Astro function example for
shutter moving actions*

Lighting:

Switching times in the morning falling into daylight are executed already at the time of sunrise (astro morning curve).

Switching times in the evening falling into daylight are executed only at the time of sunset (astro evening curve).

Example for lighting:

MON - SUN: 09:00 h lights switched off

MON - SUN: 16:15 h lights switched on

Both times fall into daylight during the whole year; this means that not the switching times indicated, but rather the astro times will be executed.



Important information:

Switching times valid for blinds/shutters and also for lighting (type: all) will be handled in the astro mode as shutter switching times.

Astro time-shift

The astro time-shift permits adapting the factory-adjusted sunrise and sunset times (cf. fig. 2.c) to individual local conditions. The maximum shift of ± 120 min is performed for all days of the year.

Example 1:

The veranda is located at the southwest side of the house. Since the sun sets in the west, it will get dark there a little later. The astro time for sunset can therefore be shifted slightly forwards (e.g. + 0:50 \Rightarrow shutter lowered 50 min later)

Example 2:

On a slope at the east side of the house it will get dark earlier than fixed by the astro curve. The astro time for sunset can therefore be shift slightly backwards (e.g. - 0:20 \Rightarrow shutter lowered 20 min earlier).

Procedure for setting up time-controlled programs

2.5.1

Confirm the info text for setting up a new program with "Next".

"Abort" returns to the main menu.

New program	
Under this item, switching times, receivers and actions can be added to a program.	
Abort	Next

2.5.2

At first, the program must be given a name.

Confirm the info text "Next".

"Abort" returns to the main menu.

New program	
Select first a name for the program.	
Abort	Next

2.5.3

Select a new name for the program from the list or select <new name> to define a new program name.

Confirm your selection with "Select".

"Back" returns to the previous screen.

New program	
<new name>	
Every morning	
Every evening	
Weekday	
Weekend	
Back	Select

2.5.4

In this screen, the selected room name can be edited or the new room name entered. The name may consist of up to 16 characters. For entering text, use the keypad (see fold-out page (3)).

"Abc" shifts between capital and small letters.

"<-" deletes the last character.

When you have entered a room name, confirm with "Ok".

"Back" returns to the previous screen.

New program	
Confirm your selection or enter a name.	

Back	Ok

2.5 Setting up time-controlled programs

2.5.5

Confirm the info text for the astro function with "Next".

"Back" returns to the previous screen.

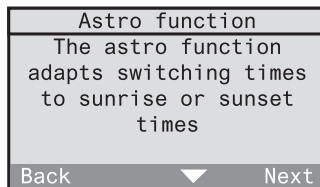

Astro function
The astro function adapts switching times to sunrise or sunset times

Back ▼ Next

2.5.6

If you want to use the astro function in this program, confirm with "Yes". The astro function can then still be added later on for individual switching times (continue with screen 2.5.7).

If you do not want to use the astro function in this program, press "No" (continue with 2.5.10).

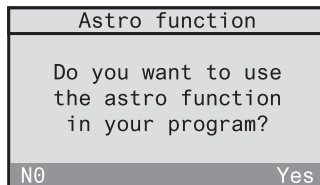

Astro function
Do you want to use the astro function in your program?

No Yes

2.5.7

In this step, the astro time-shifts for morning and evening can be set. Confirm the info text with "Next".

"Back" returns to the previous screen.

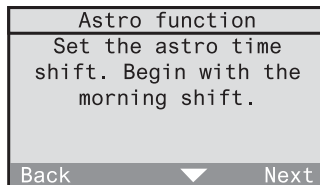

Astro function
Set the astro time shift. Begin with the morning shift.

Back ▼ Next

2.5.8

Set the shift for the morning directly with the numerical keys or with "▼" and "▲". The sign can be changed with the "*" and also with the "#" key. The maximum admissible shift is ± 120 min. Confirm your selection with "Ok".

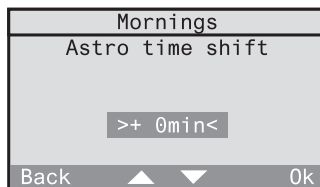

Mornings
Astro time shift

>+ 0min<

Back ▲ ▼ Ok

2.5.9

The next screen is an info screen for the astro time-shift in the evening. Confirm with "Next". Then, set the shift for the evening as described under 2.5.8.

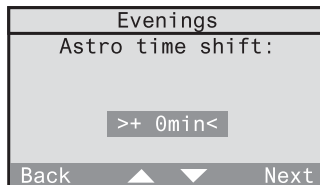

Evenings
Astro time shift:

>+ 0min<

Back ▲ ▼ Next

2.5 Setting up time-controlled programs

2.5.10

In the next step, you can fix the weekdays on which the desired action is to be performed. The action (e.g. activating the switching actuator or raising the shutter) is determined at the end of this dialog.

Confirm the info text with "Next".

"Back" returns to the previous screen.

New switching time	
Select the weekdays on which an action is to be performed.	
Back	Next

2.5.11

Select now a predefined weekday combination (in this case: Mo to Fr). The selection can still be changed in the following screen. If you want to define the days freely, select "Other".

Confirm your selection with "Select".

"Back" returns to the previous screen.

Weekday combination		
Other ...		
Daily		
Mo to Fr		
Sa and Su		
Mo to Sa		
Back	▲ ▼	Select

2.5.12

This screen displays the weekday combination. Selected days are shown underlined (in this case: Mo to Fr). If you want to change this combination, you can move the cursor in the weekday display with "<-" and "->" and add or remove a day to or from the weekday combination with "Select".

If the underlined days correspond to the desired combination, place the cursor on "Ok" and confirm with "Select".

Individual days						
Schedule						
Mo to Fr						
<u>Mo</u>	<u>Tu</u>	<u>We</u>	<u>Th</u>	<u>Fr</u>	Sa	Su
Ok						
Back	<-	->				Select

2.5.13

In the next step, you can fix the time of day at which the action is to be performed. Confirm the info text with "Next".

"Back" returns to the previous screen.

New switching time	
Select the time of day at which the action is to be performed.	
Back	Next

2.5 Setting up time-controlled programs

2.5.14

Set the time directly using the numerical keys. The time can alternatively also be changed by the minute with "▲" and "▼" slowly (brief press on the key) or fast (long press on the key). Confirm your selection with "Ok".

"Back" returns to the previous screen.

New switching time		
Set the time:		
00:00		
Back	▲ ▼	Next

2.5.15

Only if the astro function has been activated for this programm (cf. screen 2.5.6) can the astro function for the previously selected switching time be enabled with "Yes" or disabled with "No".

New switching time	
Do you want to use the astro function for this switching time?	
No	Yes

2.5.16

In the next step, select the room and the pertaining receiver which is to perform the action.

Confirm the info text with "Next".

"Back" returns to the previous screen.

New switching time	
Select the room and the respective receiver for the action.	
Back	Next

2.5.17

Select now the room in which the desired receiver is located (in this case: kitchen). You can also select "Central function". This function permits controlling several actuators of the same type in different rooms.

"Back" returns to the previous screen.

Room		
Living room		
Kitchen		
Bedroom		
Central function		
Back	▲ ▼	Select

2.5 Setting up time-controlled programs

2.5.18

The following list contains only those receiver types that are already existing in the selected room. Select first a receiver type (continue with 2.5.19). The selection of "All" permits recalling light-scenes for all existing receiver types (continue with 2.5.20).

"Back" returns to the previous screen.

Receiver types	
Dimming actuator	
Switching actuator	
Push-button actuator	
Shutter actuator	
All	
Back	Select

2.5.19

The list shows the receivers existing in the selected room (in this case: dimming actuator). Select a receiver. A group selection is also offered with "All dimmers & switches".

"Back" returns to the previous screen.

Dimming actuator	
All dimmers & switches	
Ceiling lamp	
Wall luminaire	
Back	Select

2.5.20

In a last step, select the action to be performed by the receiver.

Confirm the info text with "Next".

"Back" returns to screen 2.5.17.

New switching time	
In the last step, select the action to be performed.	
Back	Next

2.5.21

Depending on the receiver type selected above (in this case: dimming actuator), the possible actions are displayed. Select any of the actions offered. The following pages provide information on the nature of the actions performed and the pertaining receiver types.

Dimming actuator	
Switching	
Dimming	
Light-scene	
Light-control	
Back	Select

Description of performed actions



Important information:

If you program also a special function for the receiver, it is possible that after performing the action described, the receiver will moreover perform a special function. Read also chapter 3.4 "Special functions".

Switching (only with: switching and dimming actuators)

On / Off

The selected receiver is switched on and off.

Dimming (only with: dimming actuators)

Dimming level

The dimming actuator can be dimmed to a certain brightness level. Adjust the brightness level directly with the numerical keys or with "▲" and "▼".

When "Ok" is pressed for the first time, the brightness level is set in the assigned receiver for visual checking.

When "Ok" is pressed a second time, the brightness level is definitely stored and the screen terminated.

"Back" returns to the previous screen.

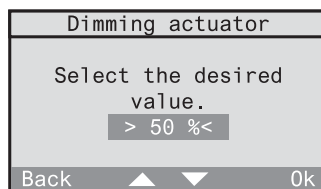

Momentary contact function (only with: push-button actuators)

Actuate

A press on the selected push-button actuator transmits a single pulse.

Light-scene (only with: switching, dimming, shutter actuators and All)

Light-scene 1-5

The lamps are set to the value of the recalled light-scene. With shutters, only one of the two limit positions can be stored in a light-scene.

All-ON / All-OFF

The All-ON resp. the All-OFF function is executed in the selected receiver.

Shutter (only with: shutter actuators)

Limit position – top / bottom

The selected shutter is moved to the upper or lower position.

Shutter movement

The selected shutter can be moved into a specific position, if the shutter moving time has been defined beforehand. Read also 2.3 "Setting the shutter moving time" in the operating instructions. 0 % corresponds to "completely up" and 100 % corresponds to "completely down". Adjust the shutter position directly with the help of the numerical keys or with "▲" and "▼".

After the first confirmation with "Ok", the position is approached for visual checking. After the second confirmation with "Ok", the position is definitely stored and the screen terminated. "Back" returns to the previous screen.

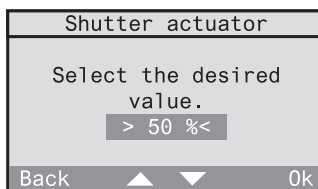

Presence (only with: All)

Leaving

The last brightness values of the lighting and the shutter end positions are stored before the All-Off telegram is transmitted.

Returning

Depending on the defined special functions (delay, action) of the radio control receiver, 3 types of reactions are available:

- **Delay: 0 min; action: <none>**
The value stored before leaving is restored on returning. Observe also the information in chapter 3.4.
- **Delay: 0 min; action: defined**
The defined action is performed on return.
- **Delay: > 0 min; action: defined**
At first, the value stored before leaving is restored on returning. The defined action is then performed at the end of the delay.

Read also chapter 5.2 "The leaving / returning function" in the operating instructions.

Light control (only with: switching and dimming actuators)

Light control on /off

If a radio control presence detector has been programmed into the receiver, the light control can be activated or deactivated here. Any other action transmitted by the radio control unit deactivates an active light control.

Adopting the lux value

If a radio presence detector has been programmed into the selected receiver, the actual brightness value can be stored in the actuator as brightness reference value (lux value) for the light control function.

2.5 Setting up time-controlled programs

2.5.22

After selection of an action, the switching time can be set. Confirm with "Ok".

"Back" returns to the selection of the action (screen 2.5.21).

New switching time	
The new switching time can now be entered.	
Back	Ok

2.5.23

To add another switching time to the program, select "Yes". The switching time for this program is then again set with the screen 2.5.10.

New switching time	
Do you want to add another switching time to the program?	
No	Yes



Modification of programs

To edit or to delete an existing program, please read chapter 3.1.3 "Modification of programs" in the operating instructions.

If the start-up dialog "new program" was called up directly from the menu, pressing "No" returns to the menu. If you are in the initial start-up, pressing "No" now displays screen 2.5.24.

2.5.24

To set up another program in the initial start-up, confirm with "Yes". "No" takes you to the next start-up dialog "new logic link".

initial start-up	
Do you want to set up further programs?	
No	Yes

2.5.25

To launch the start-up dialog "new logic link", press "Yes". Continue reading in chapter 2.6. "No" terminates the start-up and takes you back to the main menu.

Initial start-up	
Do you want to set up logic links?	
No	Yes

2.6 Setting up logic links

A logic link can be used to control a receiver from a transmitter via the radio control unit. This logic link can be set up in such a way that it is dependent on time and/or the status of another transmitter.

Example 1:

The switching actuator in the study can only be switched from the hand transmitter, if wall transmitter channel 1 in the hallway is activated (central function). As another condition, switching is to be possible only from Monday thru Friday between 18:00h and 23:00h.

Example 2:

The smoke detector is to switch on the light in the bedroom via the radio control unit in the event of smoke alarm.

The following description makes use of different terms which are defined here with reference to example 1:

Receiver (logic link):

⇒ in this case switching actuator in the study

A logic link includes a receiver which can perform an action defined by a control set. Each receiver can be assigned several control sets which are linked by a logic OR.

Control set:

The term „control set“ includes the following elements:

- ① Time (time of day and weekdays)
- ② Condition (state of transmitter)
- ③ Initiator (transmitter)
- ④ Action (only with presence detector or monitor)

① Time:

⇒ in this case Monday thru Friday between 18:00h and 23:00h

The weekdays and the duration during which the logic link can be activated. If starting and ending time are set to 00:00h, the duration is taken as a full day (24 hours).

② Condition (transmitter status):

⇒ in this case wall transmitter channel 1 active

The receiver can only be activated if the condition is fulfilled. A condition always implies a certain transmitter status.

A logic link must not necessarily include a condition.

③ Initiator (transmitter):

⇒ in this case hand transmitter

The transmitter triggering an action in your receiver, if time requirements and, if applicable, also the condition are fulfilled.

④ Action:

If a presence detector or a monitor has been selected as an initiator (transmitter), the action to be performed can also be chosen freely depending on the type of receiver.

In all other cases (e.g. channel key or light-scene of a hand transmitter) no action can be chosen, as the key-specific function will be executed.



Important information

- The "dimming" and "slat adjustment" functions are **not** supported by logic links. The dimming level or shutter position functions can be used instead.
- The "All-On" and "All-Off" keys should **not** be used as initiator or condition as the long transmit times (up to about 12 seconds) may cause delayed reactions.

2.6 Setting up logic links

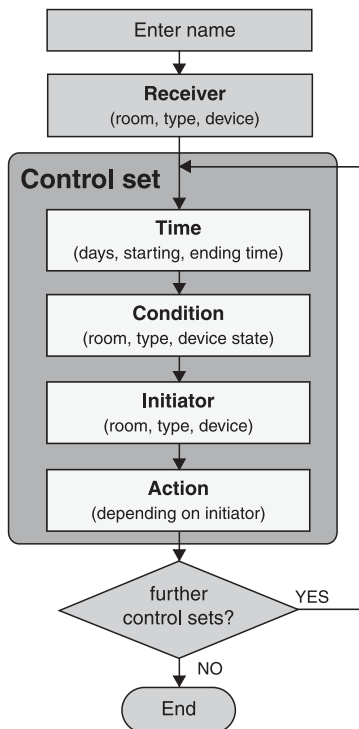

Fig. 2.e:
Logic link entry sequence

Logic links are set up with the help of the "new logic link" start-up dialog which is part of the initial start-up assistant.

To set up further new logic links even after the initial start-up, the "new logic link" start-up dialog can also be called up directly in the main menu under "Configuration – Logic link – <new logic link>".

To set up logic links, follow the dialog instructions on the display of the radio control unit.

2.6 Setting up logic links

2.6.1

Confirm the info text for setting up a new logic link with "Next".

"Abort" returns to the main menu.

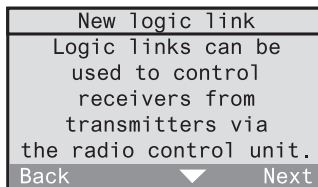

2.6.2

The logic link must first be given a name. Confirm the info text with "Next".

"Abort" returns to the main menu.

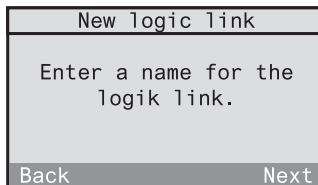

2.6.3

Select a new name for the logic link from the list or select <new name> to define a new name for the logic link. Confirm your selection with "Select".

"Back" returns to the previous screen.

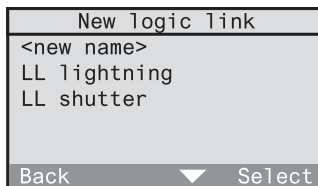

2.6.4

In this screen, the selected name can be edited or the new name entered. The name may consist of up to 16 characters. For entering text, use the keypad (see fold-out page (3)).

"Abc" shifts between capital and small letters.
"<" deletes the last character. When you have entered a name, confirm with "Ok".

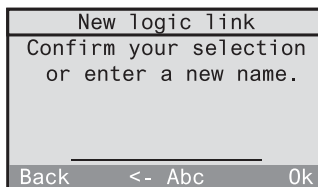

2.6 Setting up logic links

2.6.5

Select first the receiver to be incorporated into your logic link.

Confirm the info text with "Next".

"Back" returns to the previous screen.

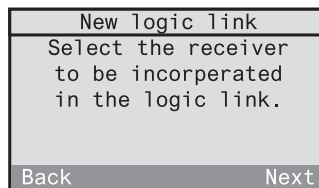

2.6.6

Select the room in which the desired receiver is located (in this case: study). To communicate with all receivers or all receivers of the same type located in other rooms, select "Central function".

"Back" returns to the previous screen.

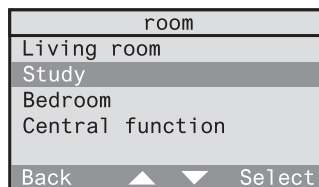

2.6.7

The following list contains only those receiver types that are already existing in the selected room. Select first a receiver type (in this case: switching actuator). The selection of "All" permits communication with all receivers in the selected room.

"Back" returns to the previous screen.

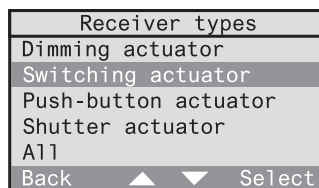

2.6.8

If a receiver type has been selected as above, a list of the receivers existing in the selected room is displayed (in this case switching actuator). Select a receiver for the logic link. The selection of a group is also possible (in this case "All dimmers and switches").

"Back" returns to the previous screen.

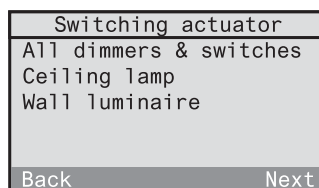

2.6 Setting up logic links

2.6.9

Define a control set for your logic link. The control set includes a time, a condition, an initiator and, if applicable, an action. Begin with the selection of the weekdays.

Confirm the info text with "Next".

"Back" returns to the previous screen.

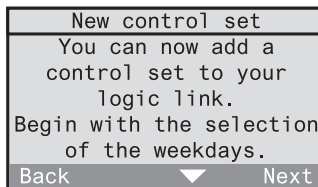

Fixing the time

At first, the weekdays and the duration during which the logic link is to be activated can be fixed.

2.6.10

Select a predefined weekday combination (in this case Mo to Fr). This combination can then still be edited in the following screen. If the days are to be chosen freely, select "Other".

Confirm your selection with "Select".

"Back" returns to the previous screen.

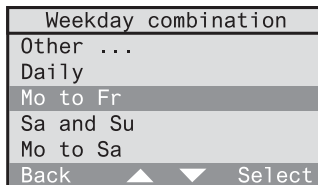

2.6.11

This screen shows the weekday combination. Selected days are underlined (in this case Mo to Fr).

If you want to change this combination, the cursor can be moved with "<-" and "->" and a day added to or removed from the combination with "Select".

When the days selected correspond to the desired combination, place the cursor on "Ok" and confirm with "Select".

"Back" returns to the previous screen.

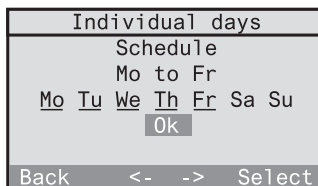

2.6 Setting up logic links

2.6.12

After selection of the weekdays, fix next the duration limited by the control set starting and ending times. Begin with the starting time. Confirm the info text with "Next".

"Back" returns to the previous screen.

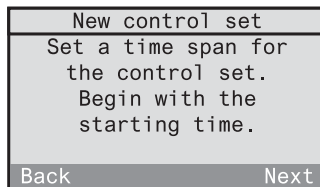

New control set
Set a time span for the control set.
Begin with the starting time.
Back Next

2.6.13

Set the starting time directly with the numerical keys.

As an alternative, the time can also be changed slowly by the minute with "▲" and "▼" (short press on the key) or fast (long press on the key). Confirm your selection with "Ok".

"Back" returns to the previous screen.

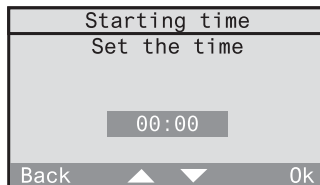

Starting time
Set the time
00:00
Back ▲ ▼ Ok

2.6.14

In the next step, the ending time must be set. Confirm the info text with "Next".

"Back" returns to the previous screen.

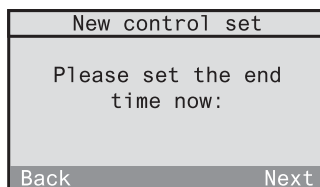

New control set
Please set the end time now:
Back Next

2.6.15

Set the ending time. If starting and ending times are both set to 00:00h, the duration of the ON time corresponds to a full day (24 h).

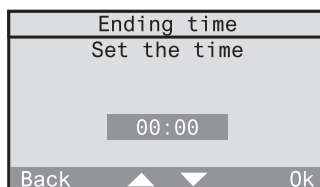

Ending time
Set the time
00:00
Back ▲ ▼ Ok

Defining a condition

In a next step, you can define a condition for the control set. The receiver can only be activated if the condition is fulfilled. The condition corresponds to a specific transmitter status (e.g. wall transmitter in hallway channel 1 activated).



Important information

The transmitter which is to be used as a condition must have been programmed into the radio control unit. It must not have been programmed into any other radio control receiver, though.

2.6.16

Confirm the info text with "Next".
"Back" returns to the previous screen.

Condition	
Conditions serve the purpose of making the control set dependent on the state of another transmitter	
Back	Next

2.6.17

If you want to use a condition in this control set, confirm with "Yes". Continue with 2.6.19. Otherwise select "No" and continue with 2.6.18.

Condition	
Do you want to use a condition in this control set?	
No	Yes

2.6.18

If you do not want a condition, the logic link is only dependent on the above selected weekday and the time of day. Confirm with "Ok" and continue with 2.6.26.
"Back" returns to the previous screen.

Condition	
You have decided not to use a condition.	
Back	Ok

2.6 Setting up logic links

2.6.19

If you want to use a condition, you must first select the radio control transmitter. Confirm the info text with "Next".

Important: A radio control detector and a smoke detector with radio control module is not suitable for use as a condition.

Condition	
Select the transmitter you want to use.	
Back	Next

2.6.20

Select the room where the desired transmitter is located (in this case: hallway).

"Back" returns to the previous screen.

Room	
Living room	
Study	
Bedroom	
Hallway	
Back	Select

2.6.21

The following list contains only types of transmitters already existing in the selected room. Select first a transmitter type (in this case: wall transmitter). Depending on the selected transmitter, observe also the instructions on the following page.

"Back" returns to the previous screen.

Transmitter types	
Hand transmitter	
Wall transmitter	
Back	Select

2.6.22

A list with the transmitters existing in the desired room (in this case: wall transmitters) appears. Select the transmitter that is to serve as a condition.

"Back" returns to the previous screen.

Wall transmitter	
WT hallway	
WT entrance	
Back	Select

2.6.23

In the next step, select first the channel and then the status of the transmitter. Confirm the info text with "Next".

"Back" returns to the previous screen.

Condition	
Select one of the channels offered and its initial state.	
Back	Next

2.6 Setting up logic links

2.6.24

Select the transmitter channel. The selection shown is dependent on the previously selected transmitter.

“Back” returns to the previous screen.

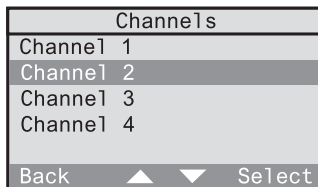

2.6.25

Finish by selecting the status fulfilling the condition.

“Back” returns to the previous screen.

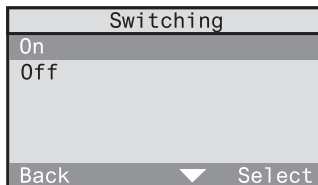

Important information for presence detectors

When a presence detector is selected as a condition, the latter is fulfilled, if it is „too bright“ or „too dark“ with respect to the brightness reference value preset on the presence detector.

Selecting an initiator (transmitter)

The following screens can be used to define the initiator of the control set. The initiator is the transmitter that triggers an action in your receiver, if the time falls into the ON-duration and if also the condition (if defined) is fulfilled.

2.6.26

Confirm the info text with "Next".

"Back" returns to the previous screen.

Initiator	
The initiator can trigger an action.	
Back	Next

2.6.27

If you want to use an initiator in this control set, confirm with "Yes". In this case, continue with 2.6.29. Otherwise, select "No" and continue with 2.6.30.

Initiator	
Do you want to use an initiator in this control set?	
No	Yes

2.6.28

If no initiator is used, the action is directly performed in the receiver by the condition. Confirm with "Ok" and continue with 2.6.35.

"Back" returns to the previous screen.

Initiator	
You have decided not to use an initiator.	
Back	Ok

2.6.29

Select the initiator (transmitter) which is to trigger the action in your receiver if the condition is fulfilled.

Initiator	
Select the transmitter you want to use.	
Back	Next

2.6 Setting up logic links

2.6.30

Select the room in which the desired transmitter (initiator) is located (in this case: study).

"Back" returns to the previous screen.

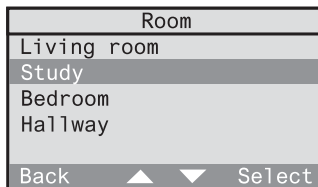

2.6.31

The following list contains only types of transmitters already existing in the selected room. Select first a transmitter type (in this case: hand transmitter).

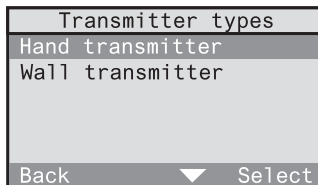

2.6.32

A list with the transmitters existing in the desired room (in this case: hand transmitters) appears. Select the transmitter that is to serve as initiator.

"Back" returns to the previous screen.

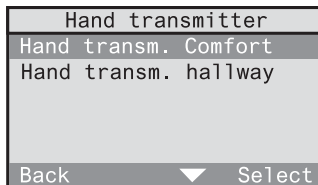

2.6.33

Select an available control element (in this case: channel key).

"Back" returns to the previous screen.

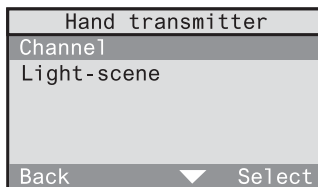

2.6.34

When a channel key of a hand transmitter is selected, a channel group selection is effected first (without illustration). The desired channel can be selected thereafter. For other control elements (e.g. light-scene) a corresponding selection is offered.

"Back" returns to the previous screen.

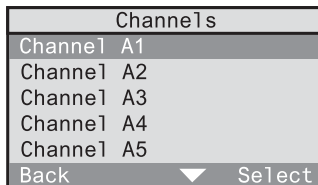

Selecting an action

When a presence detector, monitor or a smoke detector has been selected as the initiator (transmitter), the action to be performed can be freely chosen depending on the receiver.

Otherwise, the following relationships apply:

- If a specific receiver and a channel or light-scene key have been selected, no action can be chosen as the respective function (e.g. switching on / off, light-scene 3) is directly executed.
- If "All" was selected in the receiver types screen and if a channel key has been fixed as the initiator, no action can be chosen as the leaving / welcome function is directly executed.

2.6.35

Confirm the info text with "Next".

"Back" returns to the previous screen.

The screen displays a selection of possible actions or otherwise the info that no action can be chosen.

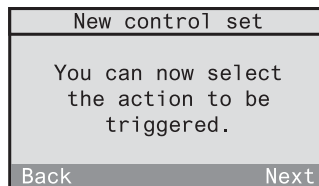

2.6.36

The control set for the selected radio control receiver is now defined. It is also possible to define further control sets for this receiver. In this case, confirm with "Yes". The definition of a new control sets begins again with screen 2.6.9.

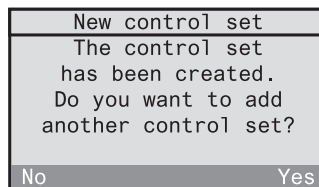



Changing logic links

To edit or to delete an established logic link, read chapter 3.2.3 "Changing logic links".

If the start-up dialog "new logic link" was called up directly from the menu, pressing "No" takes you back to the menu.

If you are in the initial start-up, pressing "No" displays screen 2.6.36.

2.6.37

To set up another logic link in the initial start-up, confirm now with "Yes". "No" terminates the initial start-up and takes you back to the menu.

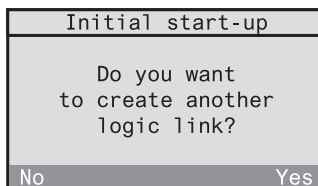

3.0 List of components

After initial start-up, a list of all programmed transmitters and receivers can be displayed for each room under "*Configuration - Components - Overview*" in the menu.

This list offers the possibility of making individual changes:

- 3.1 Changing the name of a room
- 3.2 Changing transmitters and receivers
 - Changing the name of a transmitter or receiver
 - Assigning another room to transmitters or receivers
 - Deleting a transmitter
 - Deleting a receiver
- 3.3 Programming new transmitters or receivers for existing rooms

This menu moreover permits defining special functions for individual receivers such as delay times and actions to be performed within the "Welcome" function:

- 3.4 Special functions

3.1 Changing the name of a room

To change the name of a room, select *"Configuration - Components – Overview"* in the menu.

3.1.1

A list of available rooms is displayed. Select the room whose name is to be changed (in this case: study).

"Back" returns to the previous screen.

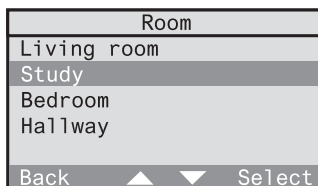

3.1.2

Select *"Change name"* in this menu.

"Back" returns to the previous screen.

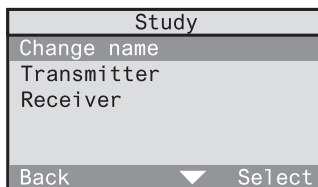

3.1.3

In this screen, the selected name can be edited or the new name entered.

For entering text, use the keypad (see fold-out page (3)).

"Abc" shifts between capital and small letters.

"<-" deletes the last character. When you have entered a name, confirm with *"Ok"*.

"Back" returns to the previous screen.

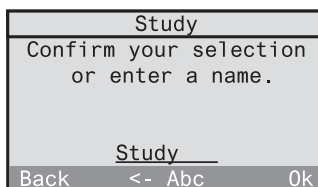

3.2 Changing of transmitters and receivers

The following changes can be made with respect to programmed transmitters and receivers:

- Changing the name of a transmitter or receiver
- Assigning another room to transmitters or receivers
- Deleting a transmitter
- Deleting a receiver

To make one of these changes, select first "*Configuration - Components - Overview*" in the menu. The example describes the selection of a transmitter for which a change is to be made. Receiver changes are made in the same way.

3.2.1

The list of available rooms is displayed. Select the room where the transmitter to be changed is located (in this case: hallway).

"Back" returns to the previous screen.

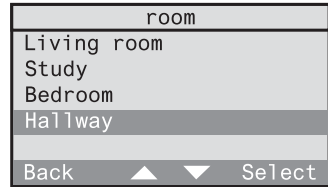

3.2.2

Select "*Transmitter*" from the menu.

"Back" returns to the previous screen.

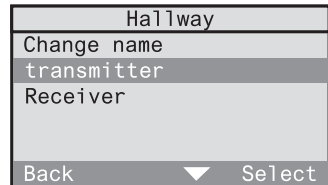

3.2.3

The list of transmitter types is displayed.

Transmitters above the line "---" are transmitter types actually existing in the selected room.

Below the line, all other transmitter types are listed.

Select the transmitter type above the line which is to be changed (in this case: wall transmitter).

"Back" returns to the previous screen.

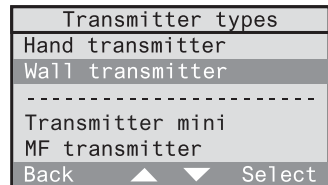

3.2 Changing of transmitters and receivers

3.2.4

A list with the wall transmitters existing in the selected room is displayed. Select the wall transmitter which is to be changed (in this case: wall transmitter in hallway).

"Back" returns to the previous screen.

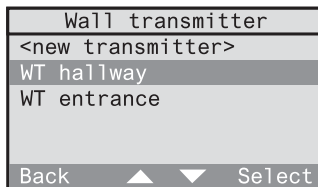

3.2.5

Select the menu item corresponding to the kind of change intended:

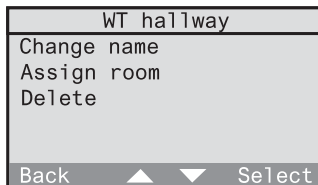

• Changing the name of a transmitter or receiver

Select "Change name" in screen 3.2.5.

3.2.6.a

In the next screen, the selected name can be edited.

For entering text, use the keypad (see fold-out page (3)).

"Abc" shifts between capital and small letters.

"<-" deletes the last character. When you have entered a name, confirm with "Ok".

"Back" returns to the previous screen.

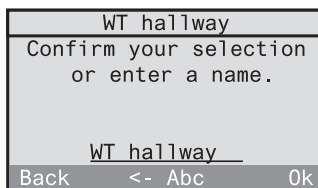

- **Assigning another room to transmitters or receivers**

Select "*Assign room*" in screen 3.2.5.

3.2.6.b

In the following screen, you can then select another room for the transmitter.

"*Back*" returns to the previous screen.

Room	
Living room	
Study	
Bedroom	
Hallway	
Back	Select

- **Deleting a transmitter**

Select "*Delete*" in screen 3.2.5.

3.2.6.c

To definitely delete the selected transmitter, answer the confirmation request with "*Yes*". Otherwise select "*No*".

Delete transmitter	
Do you really want to delete this entry?	
No	Yes

- **Deleting a receiver**

Select "*Receiver*" in screen 3.2.2 and "*Delete*" in screen 3.2.5.

3.2.6.d

To delete the selected receiver, answer the confirmation request with "*Yes*". Otherwise select "*No*".

Delete receiver	
Do you really want to delete this entry?	
No	Yes

3.2 Changing of transmitters and receivers

3.2.6.e

To delete the link between the radio control unit and the receiver completely, bring the radio control unit to within 5 m of your radio control receiver and switch the receiver into programming mode (cf. radio control receiver operating instructions).

Pressing "Next" deletes the receiver.

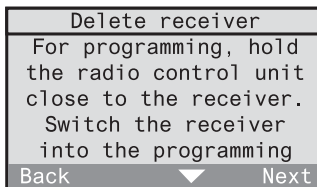

3.2.6.f

Check whether the radio control receiver has confirmed deletion (cf. radio control receiver operating instructions). Without confirmation, press "No" to repeat the deleting procedure from step 3.2.6.e onwards.

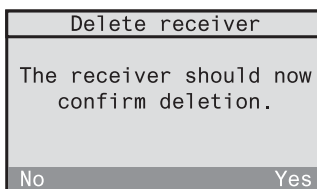

3.3 Programming new transmitters or receivers in existing rooms

Besides programming of transmitters and receivers with the initial start-up assistant, fast programming of new radio control transmitters or receivers for already existing rooms is also possible.

Start by selecting "*Configuration - Components - Overview*" from the menu.

3.3.1

A list of available rooms is displayed. Select the room for which you want to program a new transmitter or receiver (in this case: Hallway).

"*Back*" returns to the previous screen.

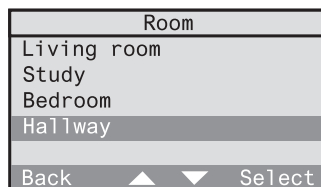

3.3.2

Select "*Transmitter*" or "*Receiver*" depending on what you want to program. The following description is an example for programming of a new transmitter. The procedure for a receiver is the same.

"*Back*" returns to the previous screen.

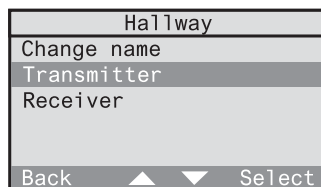

3.3.3

The list of transmitter types is displayed. Transmitters above the line "---" are transmitter types actually existing in the selected room. Below the line, all other transmitter types are listed.

Select the new transmitter type above the line which is to be programmed (in this case: wall transmitter).

"*Back*" returns to the previous screen.

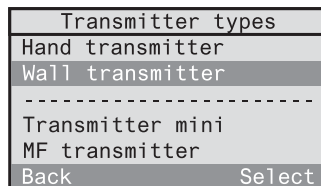

3.3 Programming new transmitters or receivers in existing rooms

3.3.4

A list of devices already existing in the selected room is displayed. Select "<new transmitter>".

"Back" returns to the previous screen.

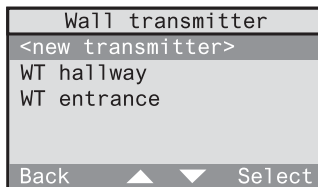

The **programming procedure for a new transmitter** will now take you thru screens 2.4.9 to 2.4.14 (cf. chapter 2.4 Programming of radio control transmitters).

The **programming procedure for a new receiver** will now take you thru screens 2.3.9 to 2.3.15 (cf. chapter 2.3 Programming of radio control receivers).

After programming, the sequence is restarted with screen 3.3.4 for adding another transmitter or receiver of the same type in the selected room, if desired.

A short press on the "Back" key will otherwise return to the previous screen or to the next higher menu level.

A long press on "Back" returns to the standard display.

3.4 Special functions (delay, action)

If required, each radio control receiver can be programmed for the special functions 'delay' and 'action'. Three different settings are available:

① **Delay: 0 min; action: <none>**

This is the preset configuration for each receiver, i.e. the respective receiver does not execute any special functions. When the returning function ('welcome' function) is called up, the value stored before leaving will be restored.

② **Delay: 0 min; action: defined**

On activation of the returning function, the respective receiver immediately executes the function defined here.

Example: switching actuator; delay: 0 min; action: on

⇒ On activation of the returning function, the switching actuator switches on.

③ **Delay: > 0 min; action: defined**

On reception of a programmed radio telegram from the RADIO CONTROL UNIT, the respective receiver executes first the corresponding action. After the defined delay, the receiver executes the action defined here under special functions.

Example: switching actuator; delay: 1 min; action: off

In addition, a logic link is defined for this switching actuator, in which a radio control detector as initiator is to switch on the radio control receiver.

⇒ On reception of a detector telegram via the radio control unit, the switching actuator is first switched on and then off again after 1 min.

⇒ On activation of the returning function, the value stored before leaving is restored. After the delay of 1 min has elapsed, the actuator switches off.



Technical information 1-channel flush-mounted switching actuator

If a 1-channel flush-mounted switching actuator which is not at least version R2 is used in your radio control system (see device rating plate), note the following special behaviour:

On activation of the leaving function or on storing of a light-scene via the radio control unit, this switching actuator **always** saves the "Off" status.

In special function setting ①, this actuator would therefore remain off on activation of the returning function.

If you prefer the "On" state instead, it is recommended to select special function setting , with

delay = 0 min; action: on

The switching actuator will then **always** switch on when the returning function is activated.

If light-scenes are stored with this actuator via the radio control unit, the device will always save the "Off" state. To save the "On" state for the light-scene, the scene must be stored with another radio control transmitter (e.g. radio control hand transmitter).

Further reading

For more details please read also the two following chapters of the operating instructions:

3.3 Working with light-scenes

5.2 The returning / leaving function



Setting of delays and actions for receivers

To set the delay time and the action for a specific receiver, select "*Configuration - Components - Overview*" from the menu.

3.4.1

Select the room where the desired receiver is located (in this case: Study).

"Back" returns to the previous screen.

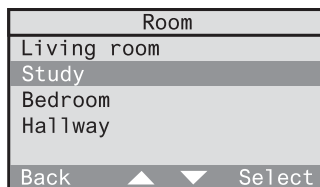

3.4.2

Select "*Receiver*" in the menu.

"Back" returns to the previous screen.

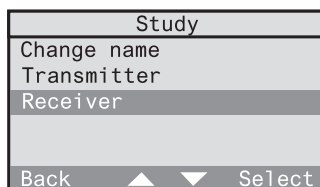

3.4.3

The list of receiver types is displayed.

Receivers above the line "---" are receiver types actually existing in the selected room. Below the line, all other receiver types are listed.

Select the receiver type above the line for which the delay and the action are to be set (in this case: Switching actuator).

"Back" returns to the previous screen.

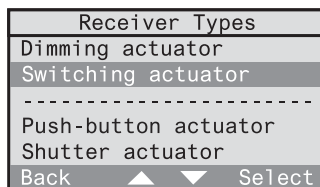

3.4.4

A list with the switching actuators existing in the selected room is displayed. Select the switching actuator for which you want to set the delay and the action (in this case: Desk).

"Back" returns to the previous screen.

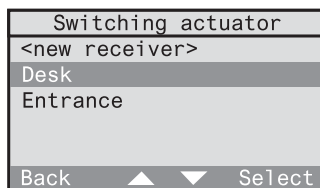

3.4 Special functions (delay, action)

3.4.5

Select here "*Special functions*".

"*Back*" returns to the previous screen.

Desk	
Change name	
Assign room	
Special functions	
Delete	
Back	▲ ▼ Select

3.4.6

Select "*Delay*" to set a delay between 0 and 240 min (interval 1 min).

Select "*Action*" to program an action into the receiver.

"*Back*" stores the adjusted values.

Desk	
Delay:	
0min	
Action	
<no function>	
Back	▼ Select

Actions: further reading



The meaning of individual actions is explained in the present fitting and start-up instructions in chapter 2.5 "Setting up time-controlled programs" on page 47.

4.0 Repeater functions

A repeater permits enlarging the transmitting and thus the working range of a radio system.



Abb. 4.a: Function of a repeater

The repeater ① receives radio telegrams ② from radio control transmitters ③ and retransmits these telegrams after a check with maximum power. The telegram is received and evaluated in a radio control receiver ④.

When a radio control unit is used in a radio control system, there are two possible variants of realizing a repeater function:

4.1 Use of an external repeater

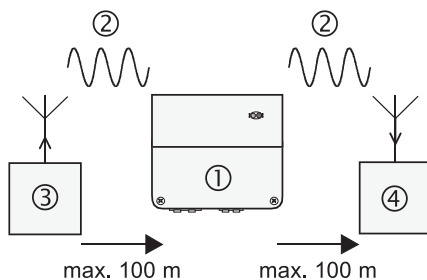
Read chapter 4.1, if you want to increase the working range of your radio system with an external repeater or if such a device is already in use.

4.2 Use of an internal repeater

Read chapter 4.2, if you want to improve the exchange of such radio signals between a transmitter and a receiver that are independent of the control unit. In this case, the radio control unit itself can be used as repeater.

4.1 Using an external repeater

An external repeater can be programmed into the radio control unit right from the beginning during the initial start-up procedure (cf. chapter 2.2). It is also possible to add an external repeater later to the radio control system.

To do so, select "*Configuration - System - Repeater*" in the menu. Confirm the info screen with "*Next*".

4.1.1

Confirm the info text with "*Next*".
"*Back*" returns to the previous screen.

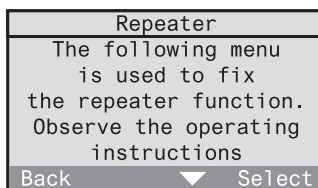

4.1.2

Select "*External repeater*".
A tick mark "✓" means that an external repeater is existing in the system, whereas "-" means that no repeater is installed. The status of the external repeater can be changed if it is selected with the "*Select*" key.

The menu item "<New entry>" is intended for use of an internal repeater. Cf. the following chapter.

"*Back*" returns to the previous screen.

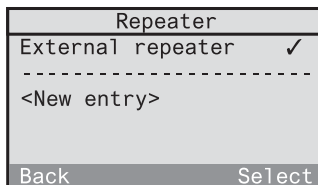

4.2 Using an internal repeater

For radio communications between a transmitter and a receiver taking place independently of the radio control control unit, i.e. not used in logic links, the internal repeater of the radio control unit itself can be used.



Abb. 4.b: Radio communication independent of the radio control unit

The internal repeater permits increasing the transmitting and thus the working range of radio communication devices.



Abb. 4.c: Use of internal repeater

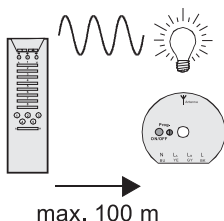

Important information

The internal repeater can handle up to 30 different radio transmitters.

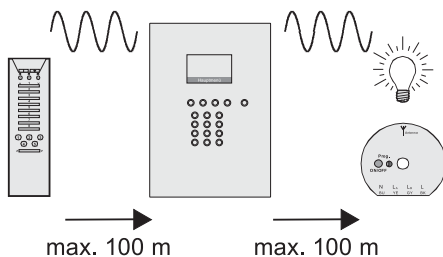
4.2 Using an internal repeater

To use the radio control unit as a repeater, start by programming your radio transmitter into the radio control unit. Cf. chapter 2.3 "Programming of radio control transmitters".

Select then "*Configuration - System - Repeater*" in the menu. Confirm the following info screen with "*Next*".

4.2.1

Select "<New entry>".

"Back" returns to the previous screen.

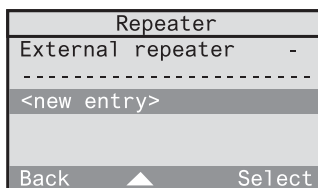

4.2.2

A list of available rooms is displayed. Select the room where your transmitter is located (in this case: Hallway).

"Back" returns to the previous screen.

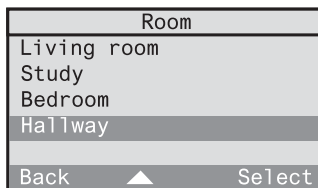

4.2.3

The following list contains the transmitter types existing in the selected room. Select the category of your transmitter (in this case: Wall transmitter).

"Back" returns to the previous screen.

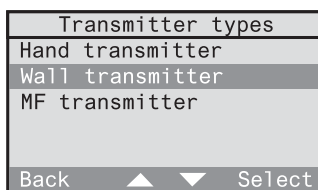

Important information

The smoke detector **cannot** be programmed into the internal radio repeater. The repeater retransmits telegrams during telegram breaks. These breaks are however needed for further communication in the event of an alarm.

4.2.4

In a last step, select your transmitter (in this case: wall transmitter desk). The transmitter is incorporated in screen 4.2.1 into the repeater list and you return to screen 4.2.1.

"Back" returns to the previous screen.

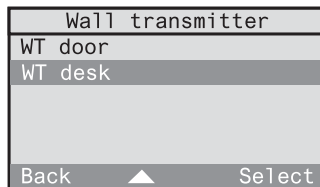

Deleting a transmitter from the repeater list

Select "*Configuration - System - Repeater*" in the menu. Confirm the following info screen with "Next".

4.2.5

A list of the transmitters making use of the internal repeater of the radio control unit is displayed. Select the transmitter you want to delete from the list (in this case: Wall transmitter desk). Confirm the following query with "Yes".

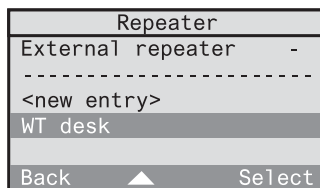

5.0 Radio control unit utilization

The radio control unit is equipped with a dynamic memory which is occupied by programmed transmitters and receivers, rooms, established programs and logic links.

The memory utilization can be displayed by the radio control unit. Select "*Configuration - System*" from the menu.

5.0.1

Select "*Information*" at the end of the system menu.

"*Back*" returns to the previous screen.

System		
Signalling volume		
Repeater		
Shutter moving time		
Master card		
Information		
Back	▲	Select

5.0.2

The following screen displays the degree of utilization of the radio control unit in percent and also the serial and version numbers (cf. "Annex B – Serial and version numbers").

Information	
Load factor:	11%
ID:	
	1: *001F 001F*
	2: *FFFF 0002*
Back	▼

Utilization – example 1:

- 5 rooms: bedroom, living room, kitchen, hallway and bathroom
- 20 radio transmitters and 20 radio receivers are in use
- 5 programs with altogether 25 switching times are existing
- 26 logic links with altogether 60 control sets are existing

⇒ **Degree of radio control unit utilization = approx. 12 %**

Utilization – example 2:

- 6 rooms: bedroom, children's room, living room, kitchen, hallway and bathroom
- 60 radio transmitters and 90 radio receivers are in use
- 18 programs with altogether 120 switching times are existing
- 60 logic links with altogether 600 control sets are existing

⇒ **Degree of radio control unit utilization = approx. 70 %**

Maximum limits

Besides the degree of utilization in percent, the following maximum limits must be observed for programming of the radio control unit:

- Receivers: max. 60 light actuators (switching or dimming actuators)
 max. 60 shutter actuators
- Transmitters: max. 60 radio transmitters per type and per room
 (transmitter types: hand transmitter, hand transmitter
 Mini, wall transmitter, multifunction sensor, universal
 transmitter, detector, presence detector, smoke detector)
- Rooms: max. 60 rooms
- Programs: max. 60 programs
 per program, 60 switching times max. can be used.
- Logic links: max. 60 logic links
 per logic link, 60 control sets max. can be used.

Manual

Operating instructions
(for the customer)

Table of contents

Operating instructions

1.0	Introduction	88
1.1	Controls and connections	89
1.2	The standard screen	91
1.3	Directions for use	94
1.3.1	The function keys	94
1.3.2	The menu functions	95
1.3.3	Entering text	96
1.4	Component list	97
2.0	Configuration	98
2.1	Basic settings	99
2.2	Setting the time	101
2.3	Setting the shutter moving time	102
2.4	Configuration menu access lock	103
3.0	Automatic mode	104
3.1	Working with programs	105
3.1.1	Setting up time-controlled programs	106
3.1.2	Activating and deactivating programs	119
3.1.3	Changing of programs	120
3.1.4	Deleting programs	137
3.1.5	Simulation of presence	138

3.2	Working with logic links	141
3.2.1	Setting up logic links	143
3.2.2	Activating and deactivating logic links	154
3.2.3	Changing logic links	155
3.2.4	Deleting logic links	164
3.3	Working with light-scenes	165
3.3.1	Storing and changing light-scenes	167
3.3.2	Recalling light-scenes	170
4.0	Manual operation	172
5.0	Extra functions	177
5.1	Using short messages	177
5.2	The returning (welcome) / leaving function	180
5.3	The Master key	182
5.4	Special functions (delay, action)	183
6.0	Project saving	187
6.1	Saving the project	188
6.2	Loading the project.....	189
7.0	Transmitter diagnosis	190

1.0 Introduction

Your electrical fitter has installed your RADIO CONTROL UNIT and put into operation for you. He has moreover performed the first software settings (e.g. by storing time-controlled programs).

The present operating instructions inform you about the designated use of a radio control unit and make you familiar with all its functions.

For more detailed information, fold out the front cover page. This page contains illustrations of all controls and connections and of the standard display screen of your radio control unit. A detailed description is given in chapters 1.1 and 1.2.



Safety warnings

Attention!

The unit must be repaired only by qualified electricians.

1.1 Controls and connections

(1) Display (7 lines of 20 characters each)

The display screen displays all data and menu entries.

The display can moreover be used to write, save and edit short messages.

(2) 4 function keys (soft-keys)

The function keys control the menu operations. The respective function of the key is indicated in the bottom line of the display.

(3) 12-key keypad

The keypad can be used to enter letters, numbers and special characters.

(4) Chip-card reader

The chip-cards supplied with the device can be used to save and to reload the actual settings. Chip-cards can also be used to expand and to update the software.

(5) Mains connection

The radio control unit is supplied with power via a mains connecting cord or a 230 V installation line.

(6) Interface (Western socket)

In future software versions, this interface can be used for data exchange with other devices.

(7) Digital input

This input can be used in future software versions to enlarge the functionality.

(8) Temperature sensor

The standard screen displays the current room temperature. This temperature is measured by the temperature sensor and is dependent on the fitting location. A temperature correction permits adaptation to the current room temperature (cf. chapter 2.1 "Basic settings").

(9) Master key

The master key can be used to call up and edit short messages or to activate the leave / welcome function. Please read also chapter 5.0 "Extra functions".

1.2 The standard screen

In everyday use, your screen shows the standard display (see fold-out page), where you can call up further functions. When the menu is displayed and when no key is pressed within ca. 1 minute, the screen goes back to the standard display.

The standard screen displays the following information:

(10) Time of day

The actual time is displayed in the 24h or 12h format. In Germany, the time can also be controlled by the DCF77 radio time signal.

(11) Weekday

Displays the actual day of the week.

(12) DCF77 field strength indicator

When setting the time, the number displayed represents the field strength of the received DCF77 signal.

The field strength indicator shows the DCF77 signal quality in the form of a number between '1' and '5'. With a '0' and a '1', reception is nearly impossible. With a '2', '3', '4' or '5', reception is possible with a higher figure corresponding to better reception. When the clock is synchronized on the time signal, the number disappears.

(13) DCF77 receive indicator

The antenna symbol shows the status of the DCF77 time signal. Three different states can be indicated:

symbol on: DCF77 time signal being received

symbol flashing: DCF77 time signal synchronizing or signal reception disturbed

no symbol: Clock actually not controlled by DCF77 time signal.

(14) Key lock

To prevent unauthorized use of the radio control unit, the keypad can be locked. To lock and unlock the key-pad, depress the  key in the standard display for ca. 1 s. The key lock function concerns only on the keys of the standard display.

(15) Short message symbol

The reception of a short message is signalled by the letter envelope symbol. In the absence of short messages, this symbol is not displayed. The short message can be called up from the menu or with the master key (9) of the radio control unit. Read also chapter 5.0 "Extra functions".

(16) Presence / absence symbol

This symbol signals the state of your radio control unit.



The respective welcome / leave function with which you can change between the 'present' and 'absent' modes, is described in chapter 5.2 "The welcome / leave function" of the operating instructions.

(17) Menu line function keys

The 4 function keys control different functions which depend on the menu line. The functions are displayed in the dark bottom line line.

(18) Temperature display

The actual room temperature is indicated in "*Degrees Celsius*" or "*Degrees Fahrenheit*".

(19) Transmit / receive indicator

When the radio control unit sends or receives telegrams, this is indicated by the letters

T (transmit)

R (receive)

Receive indicator R indicates reception of every telegram irrespective of this telegram having been programmed beforehand or not.

(20) Power supply

When the 230 V supply is o.k., no plug symbol is visible. If the power supply is disturbed or interrupted, the plug symbol flashes.

(21) Battery display

The battery symbol signals the status of the batteries inserted with three different displays:

No symbol: The batteries are in good condition.

Symbol on: In the event of power failure, the batteries can ensure an emergency operation of less than 6 hours.

Symbol flashing: The batteries must be replaced. In addition to the warning tone sounding every minute, the standard screen displays the message "Please insert new batteries". The message must be confirmed with "Ok".

Hourglass



If the hourglass symbol appears in the upper right-hand corner of the display, the radio control unit is busy and does not accept commands. Radio telegrams received during this time will be processed after the hourglass has disappeared.



Display settings

To configure the display screen, read chapter 2.0 "Settings" of the present operating instructions.

1.3 Directions for use

1.3.1 The function keys

The 4 function keys (2) are the central control elements of the radio control unit. The function of these keys depends on the text in the function key menu line (17). The function keys can all be assigned to the same function or to different functions.

In fig. 1.a, all 4 keys have the same function: pressing any of these keys will in this case display the main menu.

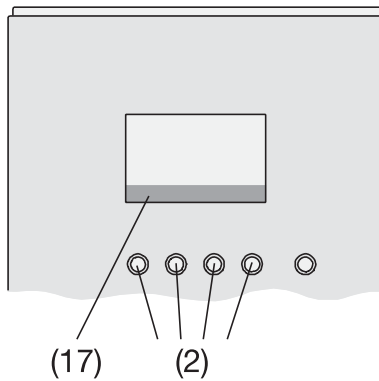

Fig. 1.a: Function of the function keys

1.3.2 The menu functions

Your radio control unit offers a number of functions and settings with which it can be optimally adapted to your requirements.

These functions are contained in menus and submenus which can be accessed with the function keys.

Access to a menu function

- In the standard display, press any of the 4 function keys (Fig. 1.b) to get into the main menu.
- In the menu, the bar can be moved with function keys 2 and 3 up (▲) and down (▼). To activate a menu item highlighted by the grey bar, press function key 4 "Select" to display the corresponding submenu of the radio control unit.

Quick selection of a menu item is also possible with the number keys of the keypad. Just press the number key corresponding to the position of the menu item (in this case: 3 for automatic). Menu items in position 10 or higher in the menu list cannot be activated with the quick-select option.

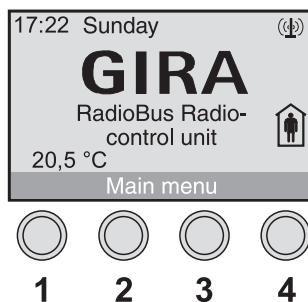

Fig. 1b: Function keys

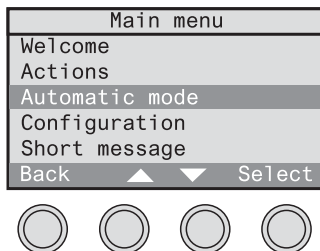

Fig. 1.c: Menu

Quitting the menu functions

To quit a submenu and get back to the next higher level, press briefly function key 1 "Back". A long press on function key 1 "Back" takes you back to the standard display.

1.3.3 Entering text

In some functions, the entry of text is possible. This concerns, for instance, the writing of short messages. Entering is done in the same way as with a mobile phone by pressing a key once or several times for each character.

Key	Character
1	Blank space 1
2 ABC	a b c 2
3 DEF	d e f 3 €
4 GHI	g h i 4
5 JKL	j k l 5
6 MNO	m n o 6
7 PQRS	p q r s 7 ß
8 TUV	t u v 8
9 WXYZ	w x y z 9
0 +	., ? ! + - 0

Please note that not all of the characters available are printed on the keys. Fig. 1.d is a list of all available characters

Examples:

- To type an "a" press key (2) once.
- To type an "e" press key (3) quickly two times.
- To type an "s" press key (7) quickly four times.
- To insert a blank, press key (1) once.

Fig. 1.d: Character assignment

To type a character using the same key as for the previous character, wait ca. 1 second before entering the new character.

1.4 Component list

For entering text, the function keys always have the same function. They can be used for text editing purposes:

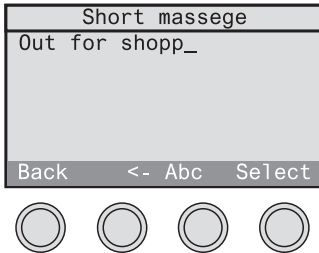

- To change between capital letters (Abc) and small letters (abc) use function key 3.
- Function key 2 "<-" can be used to delete the character last typed. To delete more than one character, keep this key pressed.

Fig. 1.e: Entering text

1.4 Component list

All radio control components (receivers and transmitters) programmed into the radio control unit are stored in the radio control unit as shown in the diagram (Fig. 1.f).

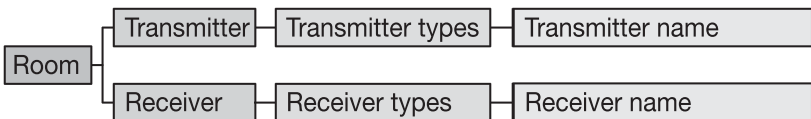

Fig. 1.f: Component list

This list simplifies in many cases the search for and the retrieval of radio control components.

Examples: Hallway - Transmitters - Wall transmitters - WT door
Kitchen - Receivers - Dimming actuators - DA dining table

2.0 Configuration

To make the use of the radio control unit as agreeable as possible for you, it is recommended to make some adjustments beforehand:

2.1 Basic settings

2.2 Setting the time

2.3 Setting the shutter moving time

2.4 Configuration menu access lock

For adjustment, select the system menu from the main menu "Configuration - System" (see fig. 2.a).

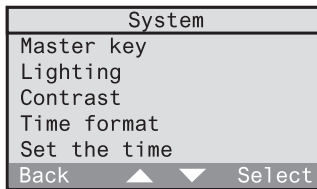

Fig. 2.a: The system menu

2.1 Basic settings

In the system menu ("*Configuration - System*") the following basic settings of your radio control unit can be made:

Lighting

always on: The display lighting is always on.

always off: The display lighting is always off.

automatic: After each key press, the display lighting is on for ca. 60 s.

To save batteries, the lighting is always off during battery operation.

Contrast

This setting adjusts the display contrast in steps from 1 to 7. Step 1 corresponds to a low contrast whereas step 7 gives high contrast.

The contrast can moreover be set by pressing the  key simultaneously with function key 2 for higher and with function key 3 for lower contrast.

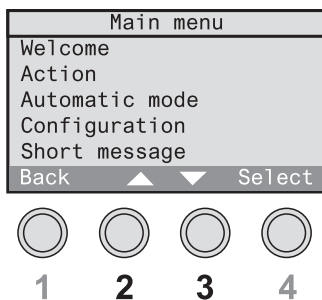

Fig. 2.b: Function keys 2 & 3

Temperature display

Select first the unit of temperature as "*degrees Celsius*" or "*degrees Fahrenheit*".

Thereafter, a temperature correction factor can be selected depending on existing ambient conditions:

degrees Celsius: selected values between + 4.0 and – 4.0 °C

degrees Fahrenheit: selected values between + 8.0 und – 8.0 °F

Loudness of signal

The signalling loudness of the integrated buzzer can be adjusted in steps between 1 and 7. Step 1 corresponds to a weak and step 7 to a loud tone signal. The tone signal can also be switched off completely.

2.2 Setting the time

For setting the time, select "*Configuration - System – Setting the time*" from the menu.

The radio control unit is equipped with a DCF77 radio receiver. Within a radius of about 1500 km from the time signal transmitter (DCF77) in Frankfurt, Germany, the date and time display can be synchronized with the signal from this station. The advantage of using the DCF77 time signal is that the time of day is always correct without any manual correction being needed.

To determine the field strength of the DCF77 signal when setting the time, the radio control unit is equipped with a field strength indicator (cf. fold-out page (12)).

The quality of the DCF77 signal received is indicated by the field strength indicator as a number between 0 and 5:

- 0, 1, 2: DCF77 reception is insufficient.
- 3: DCF77 can be received only with restrictions.
- 4: DCF77 reception is good.
- 5: DCF77 reception is very good.

The first synchronizing procedure may last between 2 and 15 minutes. When the clock is synchronized, the field strength indicator is no longer displayed.

If the reception of the DCF77 time signal is not possible, the time must be set by hand. In this case, select "*DCF off*". For manual input, follow the automatic menu guidance.

In the standard display (cf. fold-out page), the antenna symbol (13) indicates the time status. Three different states can be indicated:

- symbol on: DCF77 time signal being received
- symbol flashing: DCF77 time signal synchronizing or signal reception disturbed
- no symbol: Clock actually not controlled by DCF77 time signal.

Time format

Select either the 24h format or the 12h format for the system clock under "*Configuration - System – Time format*".

2.3 Setting the shutter moving time

For shutters with identical moving times, the radio control unit offers the possibility of moving the shutter into predefined shutter positions between 0 % (uppermost position) and 100 % (lowermost position) (Fig. 2.c). These shutter positions can be used for actions in programs or in logic links. For more information, read the corresponding chapters.

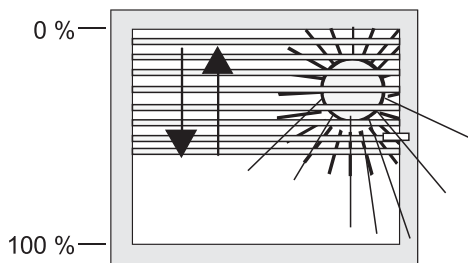

Fig. 2.c: Shutter position

Measure first the moving time of the concerned shutter from the highest to the lowest point using a stop timer. Enter the time in seconds in the menu under "Configuration - System – Shutter moving time" (Fig. 2.d). Shutter moving times between 10 s and 120 s can be set.

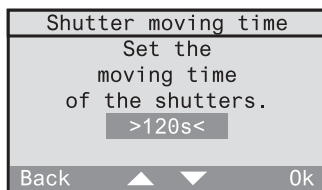

Fig. 2.d: Setting the shutter moving time

This shutter moving time is the basis for movement into all of the selected positions.

2.4 Configuration menu access lock

To protect the configuration menu against unauthorized access, an access code (PIN) can be specified. Proceed as follows:

2.4.1

Select "Configuration – Access denied" from the menu.

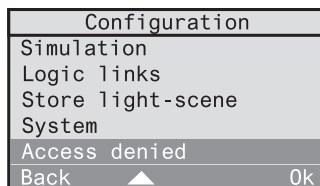

2.4.2

Specify a 1 to 4-digit PIN number for the configuration menu.

Important:

A '0' means that the access is not locked.

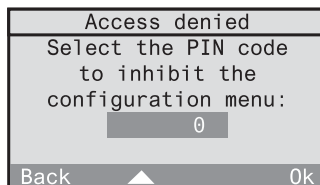

2.4.3

When the configuration menu is activated next time, the PIN number must be entered first.

Confirm with "Ok".

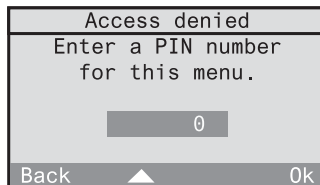

Important information:

If you have forgotten your PIN number, the menu can nevertheless be called up in spite of an active access lock. Insert a valid radio control unit Mastercard into the chip-card reader and call up the menu. You are then in the configuration menu where you should immediately either change the PIN number or set it to '0'.

3.0 Automatic mode

The radio control unit enables you to control your radio receivers for lighting and shutters in the automatic mode.

In the automatic mode, three different types of operation are available:

Time-controlled programs:

The radio control unit activates your radio control receivers depending on predefined time-controlled programs. These time-controlled programs can be activated and deactivated as desired. Read chapter 3.1 "Working with time-controlled programs".

Logic links:

By means of 'logic links', a radio control transmitter can be linked with a radio control receiver via the radio control unit. This link can be made dependent on conditions such as, for instance, allowing actions to be performed only at certain times or starting actions only after 2 transmitters have been actuated one after the other. Logic links can be activated or deactivated. Read chapter 3.2 "Working with logic links".

Light-scenes:

Your radio receivers are grouped for each room into 5 light-scenes. These light-scenes can be called up or stored separately for your lighting and your shutter. Read chapter 3.3 "Working with light-scenes".

3.1 Working with programs

A program can control your lighting and your shutters automatically depending on the time of day. You can, for instance set up and activate a program which simulates presence during your holidays.

The following chapters explain how to

- set up (chapter 3.1.1)
- activate (chapter 3.1.2)
- deactivate (chapter 3.1.2)
- modify (chapter 3.1.3)
- delete (chapter 3.1.4)

time-controlled programs.

You will also learn how to use a time-controlled program for the simulation of presence (chapter 3.1.5).

3.1.1 Setting up time-controlled programs

Your electrical fitter may already have installed some initial time-controlled programs in your radio control unit. You can, however, add further programs in accordance with your personal needs.

This is done with the help of the initial start-up dialog "new program" which can be called up in the main menu under "*Configuration – Programs – <New program>*".

To set up time-controlled programs, follow the dialog instructions on the display of your radio control unit.

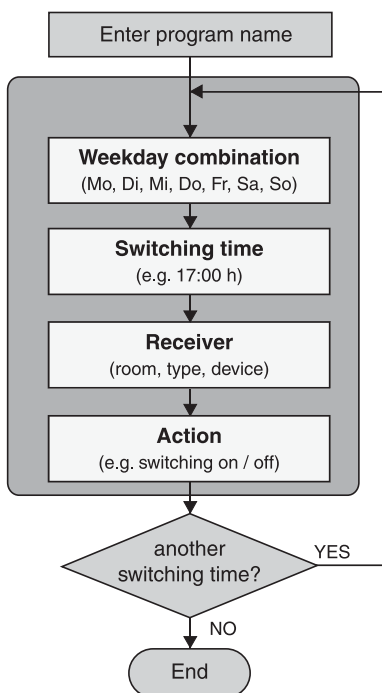
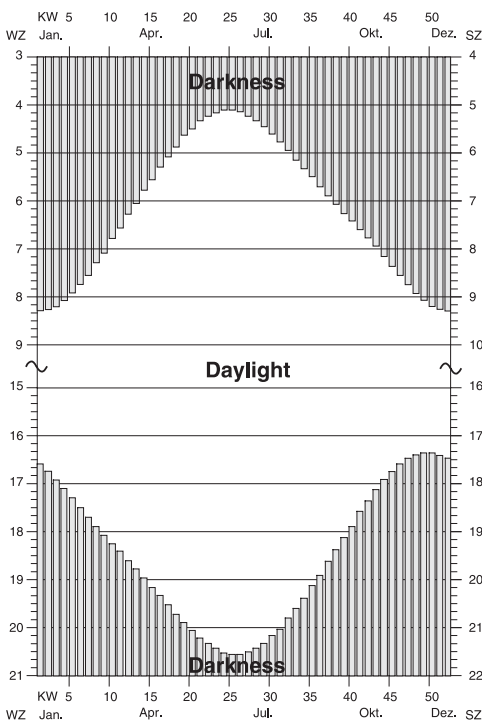

Fig.. 3.a: Program entry sequence

Astro time

The switching times stored in your programs can – if necessary – be automatically adapted to the astro time (sunset and/or sunrise times during the year). A distinction is made between switching times for blinds/shutters and lighting.



WZ: Central European winter time
SZ: Central European summer time (winter + 1 h)

Fig. 2.c:
Astro switching times over the year (approx. location: Würzburg)

When the astro function is active, the switching times will be shifted as follows:

Blind/shutter:

Switching times in the morning falling into darkness will be executed at the time of sunrise (astro morning curve).

Switching times in the evening falling into darkness will be executed at the time of sunset (astro evening curve).

3.1.1 Setting up time-controlled programs

Example for blinds/shutters:

MON - SUN: 06:30 h shutter raised

MON - SUN: 19:10 h shutter lowered

The shutter is raised in the morning at sunset – but not before 6:30 h – and is lowered in the evening at sunset – but not later than 19:10 h.

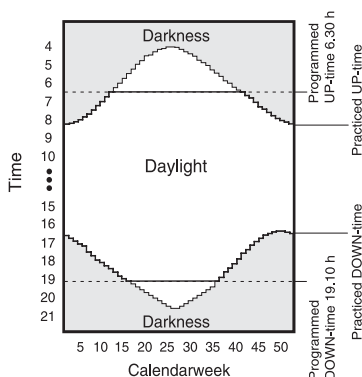

*Fig. 3.c:
Astro function example for
shutter moving actions*

Lighting:

Switching times in the morning falling into daylight are executed already at the time of sunrise (astro morning curve).

Switching times in the evening falling into daylight are executed only at the time of sunset (astro evening curve).

Example for lighting:

MON - SUN: 09:00 h lights switched off

MON - SUN: 16:15 h lights switched on

Both times fall into daylight during the whole year; this means that not the switching times indicated, but rather the astro times will be executed.



Important information:

Switching times valid for blinds/shutters and also for lighting (type: all) will be handled in the astro mode as shutter switching times.

Astro time-shift

The astro time-shift permits adapting the factory-adjusted sunrise and sunset times (cf. fig. 3.b) to individual local conditions. The maximum shift of ± 120 min is performed for all days of the year.

Example 1:

The veranda is located at the southwest side of the house. Since the sun sets in the west, it will get dark there a little later. The astro time for sunset can therefore be shifted slightly forwards (e.g. + 0:50 \Rightarrow shutter lowered 50 min later)

Example 2:

On a slope at the east side of the house it will get dark earlier than fixed by the astro curve. The astro time for sunset can therefore be shift slightly backwards (e.g. - 0:20 \Rightarrow shutter lowered 20 min earlier).

3.1.1 Setting up time-controlled programs

Procedure for setting up time-controlled programs

3.1.1.1

Confirm the info text for setting up a new program with "Next".

"Abort" returns to the main menu.

New program	
Under this item, switching times, receivers and actions can be added to a program.	
Abort	Next

3.1.1.2

At first, the program must be given a name.

Confirm the info text "Next".

"Abort" returns to the main menu.

New program	
Select first a name for the program.	
Abort	Next

3.1.1.3

Select a new name for the program from the list or select <New name> to define a new program name.

Confirm your selection with "Select".

"Back" returns to the previous screen.

New program	
<new name>	
Every morning	
Every evening	
Weekday	
Weekend	
Back	Select

3.1.1.4

In this screen, the selected room name can be edited or the new room name entered. The name may consist of up to 16 characters. For entering text, use the keypad (see fold-out page (3)).

"Abc" shifts between capital and small letters.

"<-" deletes the last character.

When you have entered a room name, confirm with "Ok".

"Back" returns to the previous screen.

New program	
Confirm your selection or enter a name.	
Back	Ok

3.1.1 Setting up time-controlled programs

3.1.1.5

Confirm the info text for the astro function with "Next".

"Back" returns to the previous screen.

Astro function		
The astro function adapts switching times to sunrise or sunset times		
Back	▼	Next

3.1.1.6

If you want to use the astro function in this program, confirm with "Yes". The astro function can then still be added later on for individual switching times (continue with screen 3.1.1.7).

If you do not want to use the astro function in this program, press "No" (continue with 3.1.1.10).

Astro function	
Do you want to use the astro function in your program?	
No	Yes

3.1.1.7

In this step, the astro time-shifts for morning and evening can be set. Confirm the info text with "Next".

"Back" returns to the previous screen.

Astro function		
Set the astro time shift. Begin with the morning shift.		
Back	▼	Next

3.1.1.8

Set the shift for the morning directly with the numerical keys or with "▼" and "▲". The sign can be changed with the "*" and also with the "#" key. The maximum admissible shift is ± 120 min. Confirm your selection with "Ok".

Mornings		
Astro time shift		
>+ 0min<		
Back	▲ ▼	Ok

3.1.1.9

The next screen is an info screen for the astro time-shift in the evening. Confirm with "Next". Then, set the shift for the evening as described under 3.1.1.8.

Evenings		
Astro time shift:		
>+ 0min<		
Back	▲ ▼	Next

3.1.1 Setting up time-controlled programs

3.1.1.10

In the next step, you can fix the weekdays on which the desired action is to be performed. The action (e.g. activating the switching actuator or raising the shutter) is determined at the end of this dialog.

Confirm the info text with *"Next"*.

"Back" returns to the previous screen.

New switching time	
Select the weekdays on which an action is to be performed.	
Back	Next

3.1.1.11

Select now a predefined weekday combination (in this case: Mo to Fr). The selection can still be changed in the following screen. If you want to define the days freely, select *"Other"*.

Confirm your selection with *"Select"*.

"Back" returns to the previous screen.

Weekday combination	
Other ...	
Daily	
Mo to Fr	
Sa and Su	
Mo to Sa	
Back	▲ ▼ Select

3.1.1.12

This screen displays the weekday combination. Selected days are shown underlined (in this case: Mo to Fr). If you want to change this combination, you can move the cursor in the weekday display with *"<-"* and *"->"* and add or remove a day to or from the weekday combination with *"Select"*.

If the underlined days correspond to the desired combination, place the cursor on *"Ok"* and confirm with *"Select"*.

Individual days	
Schedule	
Mo to Fr	
<u>Mo</u> <u>Tu</u> <u>We</u> <u>Th</u> <u>Fr</u> Sa Su	
Ok	
Back	<- -> Select

3.1.1.13

In the next step, you can fix the time of day at which the action is to be performed. Confirm the info text with *"Next"*.

"Back" returns to the previous screen.

New switching time	
Select the time of day at which the action is to be performed.	
Back	Next

3.1.1 Setting up time-controlled programs

3.1.1.14

Set the time directly using the numerical keys. The time can alternatively also be changed by the minute with "▲" and "▼" slowly (brief press on the key) or fast (long press on the key). Confirm your selection with "Ok".

"Back" returns to the previous screen.

New switching time		
Set the time:		
00:00		
Back	▲ ▼	Next

3.1.1.15

Only if the astro function has been activated for this programm (cf. screen 3.1.1.6) can the astro function for the previously selected switching time be enabled with "Yes" or disabled with "No".

New switching time	
Do you want to use the astro function for this switching time?	
No	Yes

3.1.1.16

In the next step, select the room and the pertaining receiver which is to perform the action.

Confirm the info text with "Next".

"Back" returns to the previous screen.

New switching time	
Select the room and the respective receiver for the action.	
Back	Next

3.1.1.17

Select now the room in which the desired receiver is located (in this case: kitchen). You can also select "Central function". This function permits controlling several actuators of the same type in different rooms.

"Back" returns to the previous screen.

Room		
Living room		
Kitchen		
Bedroom		
Central function		
Back	▲ ▼	Select

3.1.1 Setting up time-controlled programs

3.1.1.18

The following list contains only those receiver types that are already existing in the selected room. Select first a receiver type (continue with 2.5.19). The selection of "all" permits recalling light-scenes for all existing receiver types (continue with 3.1.1.20).

"Back" returns to the previous screen.

Receiver types	
Dimming actuator	
Switching actuator	
Push-button actuator	
Shutter actuator	
All	
Back	Select

3.1.1.19

The list shows the receivers existing in the selected room (in this case: dimming actuator). Select a receiver. A group selection is also offered with "All dimmers & switches".

"Back" returns to the previous screen.

Dimming actuator	
All dimmers & switches	
Ceiling lamp	
Wall luminaire	
Back	Select

3.1.1.20

In a last step, select the action to be performed by the receiver. Confirm the info text with "Next".

"Back" returns to screen 3.1.1.17.

New switching time	
In the last step, select the action to be performed.	
Back	Next

3.1.1.21

Depending on the receiver type selected above (in this case: dimming actuator), the possible actions are displayed. Select any of the actions offered. The following pages provide information on the nature of the actions performed and the pertaining receiver types.

Dimming actuator	
Switching	
Dimming	
Light-scene	
Light-control	
Back	Select

Description of performed actions



Important information:

If you program also a special function for the receiver, it is possible that after performing the action described, the receiver will moreover perform a special function. Read also chapter 5.4 "Special functions".

Switching (only with: switching and dimming actuators)

On / Off

The selected receiver is switched on and off.

Dimming (only with: dimming actuators)

Dimming level

The dimming actuator can be dimmed to a certain brightness level. Adjust the brightness level directly with the numerical keys or with "▲" and "▼".

When "Ok" is pressed for the first time, the brightness level is set in the assigned receiver for visual checking.

When "Ok" is pressed a second time, the brightness level is definitely stored and the screen terminated.

"Back" returns to the previous screen.

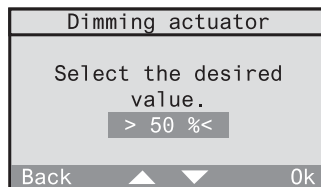

Momentary contact function (only with: push-button actuators)

Actuate

A press on the selected push-button actuator transmits a single pulse.

Light-scene (only with: switching, dimming, shutter actuators and All)

Light-scene 1-5

The lamps are set to the value of the recalled light-scene. With shutters, only one of the two limit positions can be stored in a light-scene.

All-ON / All-OFF

The All-ON resp. the All-OFF function is executed in the selected receiver.

Shutter (only with: shutter actuators)

Limit position – top / bottom

The selected shutter is moved to the upper or lower position.

Shutter movement

The selected shutter can be moved into a specific position, if the shutter moving time has been defined beforehand. Read also 2.3 "Setting the shutter moving time" in the operating instructions. 0 % corresponds to "completely up" and 100 % corresponds to "completely down". Adjust the shutter position directly with the help of the numerical keys or with "▲" and "▼".

After the first confirmation with "Ok", the position is approached for visual checking. After the second confirmation with "Ok", the position is definitely stored and the screen terminated. "Back" returns to the previous screen.

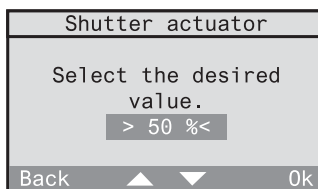

Presence (only with: All)

Leaving

The last brightness values of the lighting and the shutter end positions are stored before the All-Off telegram is transmitted.

Returning

Depending on the defined special functions (delay, action) of the radio control receiver, 3 types of reactions are available:

- **Delay: 0 min; action: <none>**
The value stored before leaving is restored on returning. Observe also the information in chapter 3.4.
- **Delay: 0 min; action: defined**
The defined action is performed on return.
- **Delay: > 0 min; action: defined**
At first, the value stored before leaving is restored on returning. The defined action is then performed at the end of the delay.

Read also chapter 5.2 "The leaving / returning function" in the present operating instructions.

Light control (only with: switching and dimming actuators)

Light control on /off

If a radio control presence detector has been programmed into the receiver, the light control can be activated or deactivated here. Any other action transmitted by the radio control unit deactivates an active light control.

Adopting the lux value

If a radio presence detector has been programmed into the selected receiver, the actual brightness value can be stored in the actuator as brightness reference value (lux value) for the light control function.

3.1.1 Setting up time-controlled programs

3.1.1.22

After selection of an action, the switching time can be set. Confirm with "Ok".

"Back" returns to the selection of the action (screen 2.5.21).

New switching time	
The new switching time can now be entered.	
Back	Ok

3.1.1.23

To add another switching time to the program, select "Yes". The switching time for this program is then again set with the screen

3.1.1.10.

New switching time	
Do you want to add another switching time to the program?	
No	Yes



Modification of programs

To edit or to delete an existing program, please read chapter 3.1.3 "Modification of programs" in the present operating instructions.

3.1.2 Activating and deactivating programs

The programs stored in your radio control unit can be activated or deactivated in accordance with your requirements. To do so, proceed as follows:

3.1.2.1

Select *"Automatic"* in the main menu.

Main menu	
Actions	
Automatic mode	
Configuration	
Short message	
Back	▲ ▼ Select

3.1.2.2

In the Automatic menu, select *"Program activation"*.

Automatic	
Activate programs	
Logic links	
Light-scenes	
Back	Select

3.1.2.3

The list of stored programs is displayed. Activated programs are marked "✓", deactivated programs are marked "-". The status of a program can be changed by selecting the corresponding program with *"Select"*.

Programs	
Holidays	-
Weekdays	✓
Weekend	-
Back	Select



Important information

- A newly created program is activated by default.
- Several programs can be active at the same time. The programs are completely independent of each other.

3.1.3 Changing programs

You can change existing programs at any time to adapt them to your requirements. The changes mentioned below will be explained in greater detail on the following pages:

- | | |
|---|----------|
| - Changing the name of a program | Page 121 |
| - Adding a new switching time | Page 122 |
| - Deleting an existing switching time | Page 123 |
| - Changing the weekdays of a switching time | Page 125 |
| - Changing a switching time | Page 127 |
| - Selecting another receiver | Page 129 |
| - Selecting another action | Page 132 |
| - Activating, deactivating or changing the astro time | Page 133 |

Changing the name of a program

3.1.3.1

Select "*Configuration - Programs*" in the menu. The list with all programs stored is displayed. Select the program whose name is to be changed (in this case: *Holidays*).

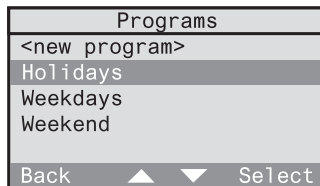

3.1.3.2

Select "*Change name*" in this menu.

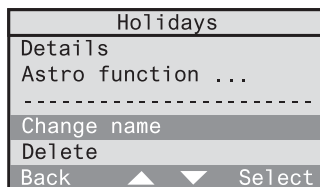

3.1.3.3

In this screen, the program name can be edited.

For entering text, use the 12-key key-pad (cf. fold-out page (3)).

"*Abc*" shifts between capital and small letters.

"<" deletes the last character. When you have entered a name, confirm with "*Ok*".

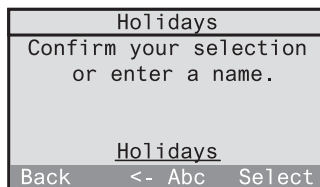

A brief press on "*Back*" returns to the previous screen or the next higher menu level.

A long press on "*Back*" returns to the standard display.

3.1.3 Changing programs

Adding a new switching time

For adding a new switching time to a program, proceed as follows:

3.1.3.4

Select "*Configuration - Programs*" in the menu. The list with all programs stored is displayed. Select the program to which you want to add a new switching time (in this case: Holidays).

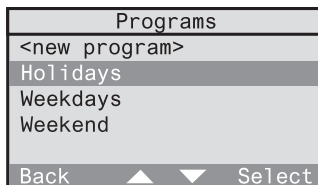

3.1.3.5

Select "*Details*" from the menu.

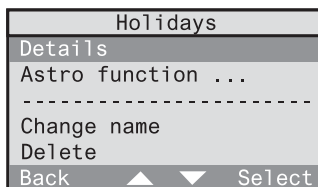

3.1.3.6

This screen shows a list of the actual switching times of the selected program. When the astro function is activated, these switching times are adapted to the astro time. Select "<new switching time>".

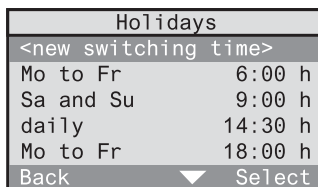

The screen displays the dialog for setting up a new switching time. The screens and the information displayed are described under 3.1.1.10 to 3.1.1.21 on pages 112-114.

A brief press on "*Back*" returns to the previous screen or the next higher menu level. A long press on "*Back*" returns to the standard display.

3.1.3 Changing programs

Deleting an existing switching time

To delete a switching time in a program, proceed as follows

3.1.3.7

Select "*Configuration - Programs*" in the menu. The list with all programs stored is displayed. Select the program in which you want to delete a switching time (in this case: Holidays).

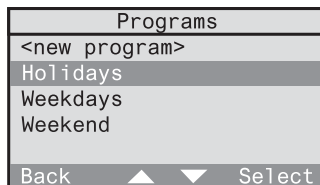

3.1.3.8

Select "*Details*" from the menu.

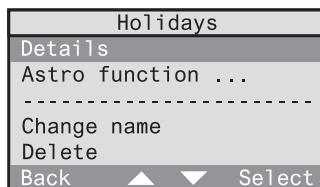

3.1.3.9

This screen shows a list of the actual switching times of the selected program. When the astro function is activated, these switching times are adapted to the astro time. Select the switching time you want to remove.

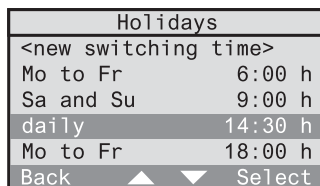

3.1.3.10

This screen shows all details of the selected switching time. Move the cursor to the end of the list by pressing "▼".

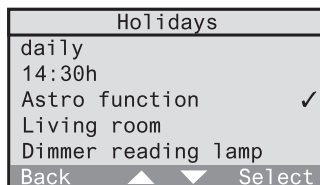

3.1.3 Changing programs

3.1.3.11

Select "*Delete*" at the end of the list to remove the selected switching time.

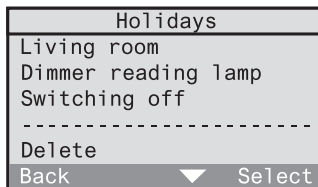

3.1.3.12

Confirm the following query with "*Yes*" to definitely delete the switching time. "*No*" returns to the previous screen.

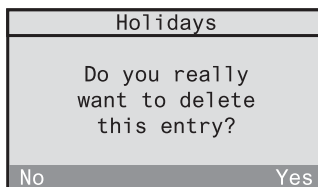

The screen displays the updated list of the switching times of the program.

A brief press on "*Back*" returns to the previous screen or the next higher menu level. A long press on "*Back*" returns to the standard display.

3.1.3 Changing programs

Changing the weekdays of a switching time

For changing the weekdays of a switching time, proceed as follows:

3.1.3.13

Select "*Configuration - Programs*" in the menu. The list with all programs stored is displayed. Select the program in which you want to change a switching time (in this case: Holidays).

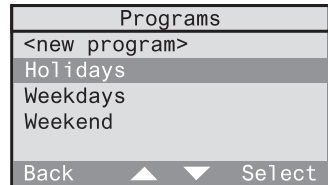

3.1.3.14

Select "*Details*" from the menu.

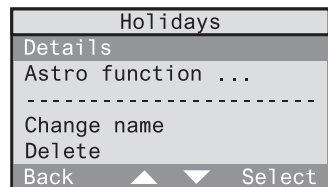

3.1.3.15

This screen shows a list of the actual switching times of the selected program. When the astro function is activated, these switching times are adapted to the astro time. Select the switching time the weekdays of which you want to change.

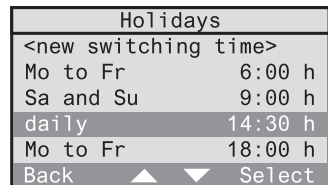

3.1.3.16

This screen shows all details of the selected switching time. Highlight the weekday option (in this case: Daily) and confirm with "*Select*".

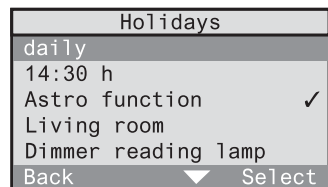

3.1.3 Changing programs

3.1.3.17

Select now a predefined weekday combination (in this case: Mo to Fr). The selection can still be changed in the following screen. If you want to define the days freely, select "Other". Confirm your selection with "Select".

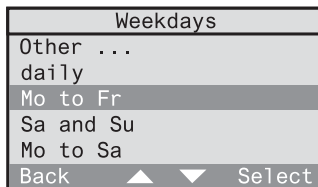

3.1.3.18

This screen displays the weekday combination. Selected days are shown underlined (in this case: Mo to Fr). If you want to change this combination, you can move the cursor in the weekday display with "<- " and "->" and add or remove a day to or from the weekday combination with "select". If the underlined days correspond to the desired combination, place the cursor on "Ok" and confirm with "Select".

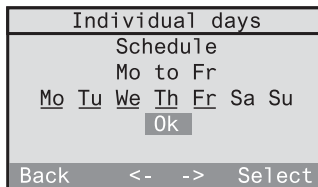

The screen displays the list of the switching times of the program updated by new weekdays.

A brief press on "Back" returns to the previous screen or the next higher menu level. A long press on "Back" returns to the standard display.

3.1.3 Changing programs

Changing a switching time

For changing a switching time in an existing program, proceed as follows:

3.1.3.19

Select "*Configuration - Programs*" in the menu. The list with all programs stored is displayed. Select the program in which you want to change a switching time (in this case: Holidays).

Programs	
<new program>	
Holidays	
Weekdays	
Weekend	
Back	Select

3.1.3.20

Select "*Details*" from the menu.

Holidays	
Details	
Astro function ...	

Change name	
Delete	
Back	Select

3.1.3.21

This screen shows a list of the actual switching times of the selected program. When the astro function is activated, these switching times are adapted to the astro time. Select the switching time you want to change.

Holidays	
<new switching time>	
Mo to Fr	6:00 h
Sa and Su	9:00 h
daily	14:30 h
Mo to Fr	18:00 h
Back	Select

3.1.3.22

This screen shows all details of the selected switching time. Highlight the time (in this case: 14:30 h) and confirm with "*Select*".

Holidays	
daily	
14:30 h	
Astro function	✓
Living room	
Dimmer reading lamp	
Back	Select

3.1.3 Changing programs

3.1.3.23

Set the switching time directly with the numerical keys. The time can also be changed by the minute with "▲" and "▼" slowly (brief press on the key) or fast (long press on the key). Confirm your selection with "Ok".

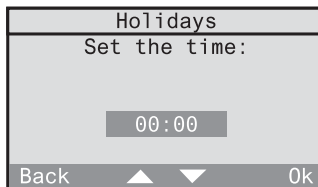

The screen displays the list of the switching times of the program updated by the time.

A brief press on "Back" returns to the previous screen or the next higher menu level. A long press on "Back" returns to the standard display.

Selecting another receiver

The receiver assigned to a given switching time can be changed. Two possible cases must be distinguished: the new receiver is located in the same room or in another room.

3.1.3.24

Select "*Configuration - Programs*" in the menu. The list with all programs stored is displayed. Select the program in which you want to change the receiver for a given switching time (in this case: Holidays).

Programs	
<new program>	
Holidays	
Weekdays	
Weekend	
Back	▲ ▼ Select

3.1.3.25

Select "*Details*" from the menu.

Holidays	
Details	
Astro function ...	

Change name	
Delete	
Back	▲ ▼ Select

3.1.3.26

This screen shows a list of the actual switching times of the selected program. When the astro function is activated, these switching times are adapted to the astro time. Select the switching time for which you want to change the receiver.

Holidays	
<new switching time>	
Mo to Fr	6:00 h
Sa and Su	9:00 h
daily	14:30 h
Mo to Fr	18:00 h
Back	▲ ▼ Select

3.1.3 Changing programs

3.1.3.27

This screen shows the details of the selected switching time.

If the new receiver is located in another room, select this room (in this case: Living room).

⇒ Continue with screen 3.1.3.28.

If the new receiver is located in the same room, select the actual receiver (in this case: Lighting).

⇒ Continue with screen 3.1.3.29.

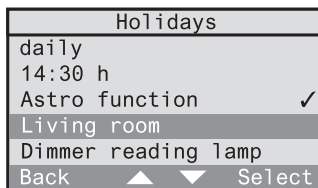

3.1.3.28

The list of existing rooms is displayed. Select the room where the new receiver is located.

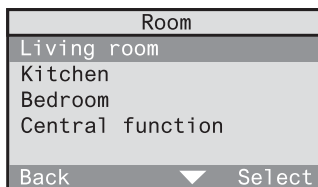

3.1.3.29

The list of all receiver types existing in your room is displayed. Select the type of the new receiver (in this case: Dimming actuator).

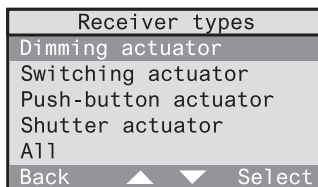

3.1.3.30

The list with the receivers of the selected type existing in the room is displayed (in this case: Dimming actuators).

Select your new receiver.

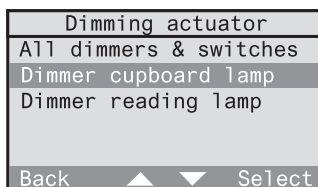

3.1.3 Changing programs

3.1.3.31

The possible actions depending on receiver type (in this case: Dimming actuator) are displayed. Select the desired action.

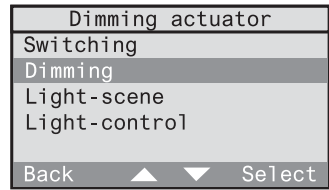

Description of performed actions

The individual actions are described in the present operating instructions in chapter 3.1.1. "Setting up time-controlled programs" on page 115.

3.1.3 Changing programs

Selecting another action

The action performed at a given switching time in a program can be changed. Proceed as follows:

3.1.3.32

Select "*Configuration - Programs*" in the menu. The list with all programs stored is displayed. Select the program in which you want to change the receiver for a given switching time (in this case: Holidays).

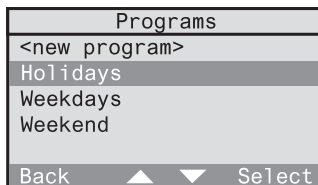

3.1.3.33

Select "*Details*" from the menu.

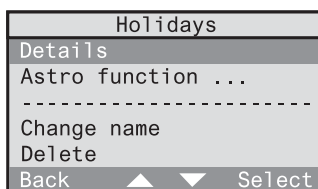

3.1.3.34

This screen shows a list of the actual switching times of the selected program. When the astro function is activated, these switching times are adapted to the astro time. Select the switching time for which you want to change the action to be performed.

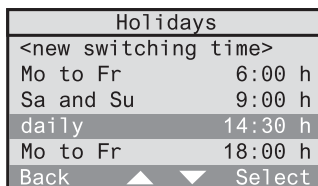

3.1.3.35

This screen shows the details of the selected switching time.

Select the action to be changed at the end of the list (in this case: Switching off).

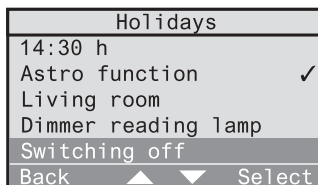

A list with the possible actions that can be selected is displayed. The remaining procedure is identical with that for "Selecting another receiver" from screen 3.1.3.31 on page 131 onwards.

Activating, deactivating or changing the astro time

You can make the following changes:

- activate or deactivate the astro time in a program
- activate or deactivate the astro time in a given switching time
- change the astro time shift

a) Activating or deactivating the astro time in a program

3.1.3.36

Select "*Configuration - Programs*" in the menu. The list with all programs stored is displayed. Select the program for which you want to activate or deactivate the astro time (in this case: Holidays).

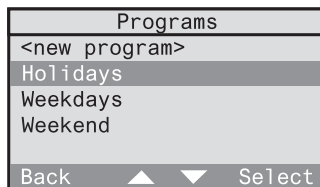

3.1.3.37a

If astro time is not activated in the selected program, the screen displays "*Astro function off*". Select this item to activate the astro function and follow the dialog in 3.1.1.5 to 3.1.1.9 (cf. chapter 3.1.1).

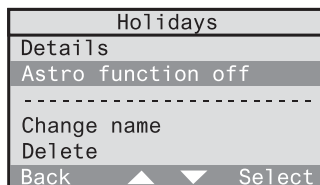

3.1.3.37b

If astro time is activated in the selected program, the screen displays "*Astro function...*". Select this to deactivate the astro function in the following screen for the whole program.

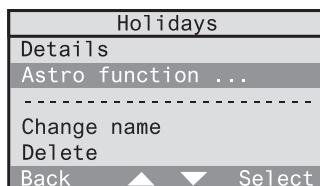

3.1.3 Changing programs

3.1.3.38

Select "*Deactivate*" to deactivate the astro function for this program.

Astro function	
Morning:	0 min
Evening:	0 min
Deactivate	
Back	▲ Select

b) Activating or deactivating the astro time for the switching time

If the astro function is activated, the astro function can be activated or deactivated individually for each switching time of the program.

3.1.3.39

Select "*Configuration - Programs*" in the menu. The list with all programs stored is displayed. Select the program in which you want to activate or deactivate the astro time in individual switching times (in this case: Holidays).

Programs	
<new program>	
Holidays	
Weekdays	
Weekend	
Back	▲ ▼ Select

3.1.3.40

Select "*Details*" from the menu.

Holidays	
Details	
Astro function ...	

Change name	
Delete	
Back	▲ ▼ Select

3.1.3.41

This screen shows all stored switching times of the selected program. These switching times are adapted to the astro time when the astro function is activated. Select the switching time in which you want to activate or deactivate the astro time.

Holidays	
<new switching time>	
Mo to Fr	6:00 h
Sa and Su	9:00 h
daily	14:30 h
Mo to Fr	18:00 h
Back	▲ ▼ Select

3.1.3 Changing programs

3.1.3.42

Select "*Astro function*". The symbols have the following meaning:

✓: astro function is activated

–: astro function is deactivated

By pressing "*select*" you can alternate between activated and deactivated for this switching time.

Holidays	
Mo to Fr	
6:00 h	
Astro function	✓
Kitchen	
Window shutter	
Back	▲ ▼ Select

c) Changing the astro time shift

If you want to change the astro time shift in a program, proceed as follows:

3.1.3.43

Select "*Configuration - Programs*" in the menu. The program list showing all programs stored is displayed. Select the program in which you want to change the astro time shift (in this case: Holidays).

Programs	
<new program>	
Holidays	
Weekdays	
Weekend	
Back	▲ ▼ Select

3.1.3.44

To display an overview of both astro time shifts, select "*Astro function ...*".

Holidays	
Details	
Astro function ...	

Change name	
Delete	
Back	▲ ▼ Select

3.1.3.45

Then select the astro time shift you want to change (in this case: Evening).

Astro function	
Morning:	0 min
Evening:	0 min
Deactivate	
Back	▲ Select

3.1.3 Changing programs

3.1.3.46

Select the shift directly with the numerical keys or with "▲" en "▼". The sign can be changed with the "*" and also with the "#" key. The maximum shift is ± 120 min. Confirm your selection with "Ok".

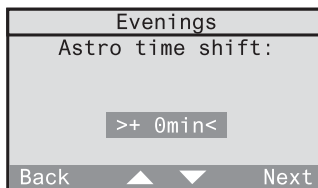

3.1.4 Deleting programs

To delete a complete program, proceed as follows:

3.1.4.1

Select "*Configuration - Programs*" in the menu. The list with all programs stored is displayed. Select the program you want to delete (in this case: Holidays).

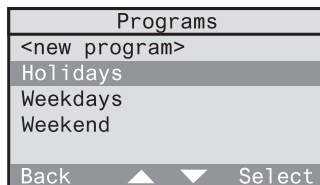

3.1.4.2

Select "*Delete*" in this menu.

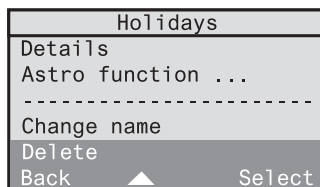

3.1.4.3

To delete the program, answer the confirmation request with "Yes". "No" returns to the previous screen.

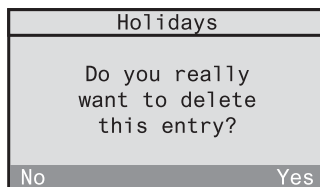

A brief press on "*Back*" returns to the previous screen or the next higher menu level. A long press on "*Back*" returns to the standard display.

3.1.5 Simulation of presence

The radio control unit offers the possibility of selecting a time-controlled program to simulate presence in the house. All the switching times of this program will then be varied during your absence with a random delay of ± 15 minutes.

To fix a program as presence simulation program, select "*Configuration - Simulation*" in the menu.

3.1.5.1

Confirm the info screen with "*Next*".

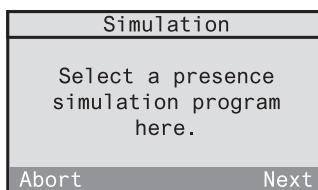

3.1.5.2

An overview of the programs stored is displayed. Select the program you want to use for presence simulation (in this case: Holidays).

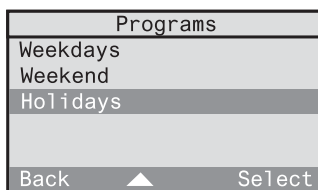

3.1.5.3

The selected program is identified as simulation program and displayed above the broken line.

"*Back*" returns to the menu.

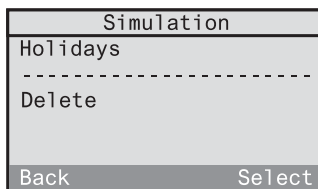

Changing or deleting the presence simulation program

To fix another program as presence simulation program, select the old program (in this case: Holidays) in screen 3.1.5.3. You are then taken back to screen 3.1.5.2 from where another program can be selected.

To delete the selected program as presence simulation program, select "*Delete*" in screen 3.1.5.3. The program as such is not deleted and continues to be available as a normal program without simulation function.

Activating and deactivating of the presence simulation function

A program defined as presence simulation program is activated by the leaving function and deactivated by the returning (welcome) function, independent of whether the program is activated or deactivated in the program list.



Read chapter 5.2 "The returning (welcome) / leaving function".

3.2 Setting up logic links

A logic link can be used to control a receiver from a transmitter via the radio control unit. This logic link can be set up in such a way that it is dependent on time and/or the status of another transmitter.

Example 1:

The switching actuator in the study can only be switched from the hand transmitter, if wall transmitter channel 1 in the hallway is activated (central function). As another condition, switching is to be possible only from Monday thru Friday between 18:00h and 23:00h.

Example 2:

The smoke detector is to switch on the light in the bedroom via the radio control unit in the event of smoke alarm.

The following description makes use of different terms which are defined here with reference to example 1:

Receiver (logic link):

⇒ in this case switching actuator in the study

A logic link includes a receiver which can perform an action defined by a control set. Each receiver can be assigned several control sets which are linked by a logic OR.

Control set:

The term "control set" includes the following elements:

- ① Time (time of day and weekdays)
- ② Condition (state of transmitter)
- ③ Initiator (transmitter)
- ④ Action (only with presence detector or monitor)

① Time:

⇒ in this case Monday thru Friday between 18:00h and 23:00h

The weekdays and the duration during which the logic link can be activated. If starting and ending time are set to 00:00h, the duration is taken as a full day (24 hours).

② Condition (transmitter status):

⇒ in this case wall transmitter channel 1 active

The receiver can only be activated if the condition is fulfilled. A condition always implies a certain transmitter status.

A logic link must not necessarily include a condition.

③ Initiator (transmitter):

⇒ in this case hand transmitter

The transmitter triggering an action in your receiver, if time requirements and, if applicable, also the condition are fulfilled.

④ Action:

If a presence detector or a monitor has been selected as an initiator (transmitter), the action to be performed can also be chosen freely depending on the type of receiver.

In all other cases (e.g. channel key or light-scene of a hand transmitter) no action can be chosen, as the key-specific function will be executed.

Important information



- The "dimming" and "slat adjustment" functions are **not** supported by logic links. The dimming level or shutter position functions can be used instead.
- The "All-On" and "All-Off" keys should **not** be used as initiator or condition as the long transmit times (up to about 12 seconds) may cause delayed reactions.

The following chapters explain how to

- set up (chapter 3.2.1)
- activate (chapter 3.2.2)
- deactivate (chapter 3.2.2)
- change (chapter 3.2.3)
- delete (chapter 3.2.4)

logic links.

3.2.1 Setting up logic links

Your electrical fitter may already have installed some initial logic links in your radio control unit. You can, however, add further logic links in accordance with your personal needs.

This is done with the help of the initial start-up dialog "new logic links" which can be called up in the main menu under "Configuration – Logic links – <New logic link>".

To set up a new logic link, follow the dialog instructions on the display of your radio control unit.

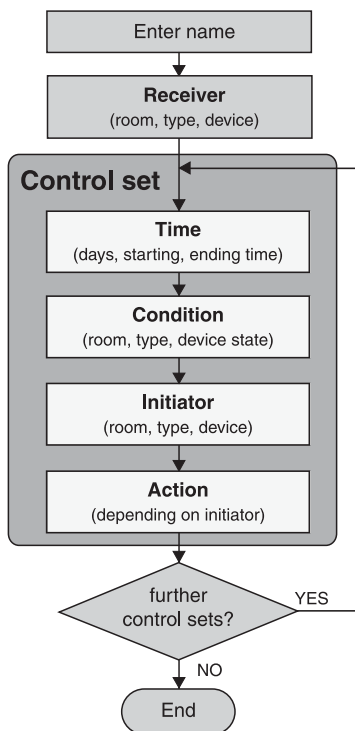

Fig. 3.d: Logic link set-up sequence

3.2.1 Setting up logic links

3.2.1.1

Confirm the info text for setting up a new logic link with "Next".

"Abort" returns to the main menu.

New logic link		
Logic links can be used to control receivers from transmitters via the radio control unit.		
Back	▼	Next

3.2.1.2

The logic link must first be given a name.

Confirm the info text with "Next".

"Abort" returns to the main menu.

New logic link	
Enter a name for the logic link.	
Back	Next

3.2.1.3

Select a new name for the logic link from the list or select <New name> to define a new name for the logic link. Confirm your selection with "Select".

"Back" returns to the previous screen.

New logic link		
<new name>		
LL lightning		
LL shutter		
Back	▼	Select

3.2.1.4

In this screen, the selected name can be edited or the new name entered. The name may consist of up to 16 characters. For entering text, use the keypad (see fold-out page (3)).

"Abc" shifts between capital and small letters.
"<-" deletes the last character. When you have entered a name, confirm with "Ok".

New logic link			
Confirm your selection or enter a new name.			
Back	<-	Abc	Ok

3.2.1 Setting up logic links

3.2.1.5

Select first the receiver to be incorporated into your logic link.

Confirm the info text with "Next".

"Back" returns to the previous screen.

New logic link	
Select the receiver to be incorporated in the logic link.	
Back	Next

3.2.1.6

Select the room in which the desired receiver is located (in this case: study). To communicate with all receivers or all receivers of the same type located in other rooms, select "*Central function*".

"Back" returns to the previous screen.

room	
Living room	
Study	
Bedroom	
Central function	
Back	▲ ▼ Select

3.2.1.7

The following list contains only those receiver types that are already existing in the selected room. Select first a receiver type (in this case: switching actuator). The selection of "All" permits communication with all receivers in the selected room.

"Back" returns to the previous screen.

Receiver types	
Dimming actuator	
Switching actuator	
Push-button actuator	
Shutter actuator	
All	
Back	▲ ▼ Select

3.2.1.8

If a receiver type has been selected as above, a list of the receivers existing in the selected room is displayed (in this case switching actuator). Select a receiver for the logic link. The selection of a group is also possible (in this case "*All dimmers and switches*").

"Back" returns to the previous screen.

Switching actuator	
All dimmers & switches	
Ceiling lamp	
Wall luminaire	
Back	Next

3.2.1 Setting up logic links

3.2.1.9

Define a control set for your logic link. The control set includes a time, a condition, an initiator and, if applicable, an action. Begin with the selection of the weekdays.

Confirm the info text with "Next".

"Back" returns to the previous screen.

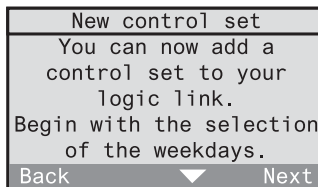

Fixing the time

At first, the weekdays and the duration during which the logic link is to be activated can be fixed.

3.2.1.10

Select a predefined weekday combination (in this case Mo to Fr). This combination can then still be edited in the following screen. If the days are to be chosen freely, select "Other".

Confirm your selection with "Select".

"Back" returns to the previous screen.

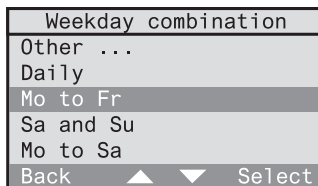

3.2.1.11

This screen shows the weekday combination. Selected days are underlined (in this case Mo to Fr).

If you want to change this combination, the cursor can be moved with "<- " and "-> " and a day added to or removed from the combination with "Select".

When the days selected correspond to the desired combination, place the cursor on "Ok" and confirm with "Select".

"Back" returns to the previous screen.

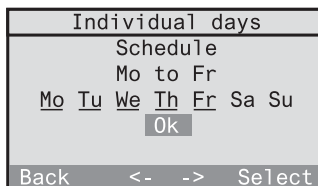

3.2.1 Setting up logic links

3.2.1.12

After selection of the weekdays, fix next the duration limited by the control set starting and ending times. Begin with the starting time. Confirm the info text with "Next".

"Back" returns to the previous screen.

New control set	
Set a time span for the control set. Begin with the starting time.	
Back	Next

3.2.1.13

Set the starting time directly with the numerical keys.

As an alternative, the time can also be changed slowly by the minute with "▲" and "▼" (short press on the key) or fast (long press on the key). Confirm your selection with "Ok".

"Back" returns to the previous screen.

Starting time		
Set the time		
00:00		
Back	▲ ▼	Ok

3.2.1.14

In the next step, the ending time must be set. Confirm the info text with "Next".

"Back" returns to the previous screen.

New control set	
Please set the end time now:	
Back	Next

3.2.1.15

Set the ending time. If starting and ending times are both set to 00:00h, the duration of the ON time corresponds to a full day (24 h).

Ending time		
Set the time		
00:00		
Back	▲ ▼	Ok

Defining a condition

In a next step, you can define a condition for the control set. The receiver can only be activated if the condition is fulfilled. The condition corresponds to a specific transmitter status (e.g. wall transmitter in hallway channel 1 activated).



Important information

The transmitter which is to be used as a condition must have been programmed into the radio control unit. It must not have been programmed into any other radio control receiver, though.

3.2.1.16

Confirm the info text with "Next".
"Back" returns to the previous screen.

Condition	
Conditions serve the purpose of making the control set dependent on the state of another transmitter	
Back	Next

3.2.1.17

If you want to use a condition in this control set, confirm with "Yes". Continue with 3.2.1.19. Otherwise select "No" and continue with 3.2.1.18.

Condition	
Do you want to use a condition in this control set?	
No	Yes

3.2.1.18

If you do not want a condition, the logic link is only dependent on the above selected weekday and the time of day. Confirm with "Ok" and continue with 3.2.1.26.
"Back" returns to the previous screen.

Condition	
You have decided not to use a condition.	
Back	Ok

2.6 Setting up logic links

3.2.1.19

If you want to use a condition, you must first select the radio control transmitter. Confirm the info text with "Next".

Important: A radio control detector and a smoke detector with radio control module is not suitable for use as a condition.

Condition	
Select the transmitter you want to use.	
Back	Next

3.2.1.20

Select the room where the desired transmitter is located (in this case: hallway).

"Back" returns to the previous screen.

Room	
Living room	
Study	
Bedroom	
Hallway	
Back	Select

3.2.1.21

The following list contains only types of transmitters already existing in the selected room. Select first a transmitter type (in this case: wall transmitter). Depending on the selected transmitter, observe also the instructions on the following page.

"Back" returns to the previous screen.

Transmitter types	
Hand transmitter	
Wall transmitter	
Back	Select

3.2.1.22

A list with the transmitters existing in the desired room (in this case: wall transmitters) appears. Select the transmitter that is to serve as a condition.

"Back" returns to the previous screen.

Wall transmitter	
WT hallway	
WT entrance	
Back	Select

3.2.1.23

In the next step, select first the channel and then the status of the transmitter. Confirm the info text with "Next".

"Back" returns to the previous screen.

Condition	
Select one of the channels offered and its initial state.	
Back	Next

3.2.1 Setting up logic links

3.2.1.24

Select the transmitter channel. The selection shown is dependent on the previously selected transmitter.

"Back" returns to the previous screen.

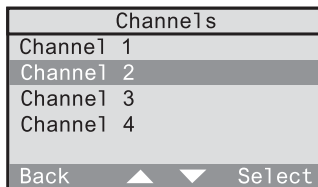

3.2.1.25

Finish by selecting the status fulfilling the condition.

"Back" returns to the previous screen.

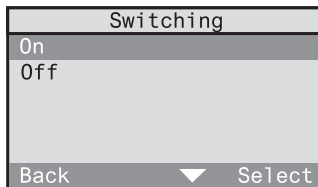

Important information for presence detectors

When a presence detector is selected as a condition, the latter is fulfilled, if it is "too bright" or "too dark" with respect to the brightness reference value preset on the presence detector.

Selecting an initiator (transmitter)

The following screens can be used to define the initiator of the control set. The initiator is the transmitter that triggers an action in your receiver, if the time falls into the ON-duration and if also the condition (if defined) is fulfilled.

3.2.1.26

Confirm the info text with *"Next"*.

"Back" returns to the previous screen.

Initiator	
The initiator can trigger an action.	
Back	Next

3.2.1.27

If you want to use an initiator in this control set, confirm with *"Yes"*. In this case, continue with 3.2.1.29. Otherwise, select *"No"* and continue with 3.2.1.30.

Initiator	
Do you want to use an initiator in this control set?	
No	Yes

3.2.1.28

If no initiator is used, the action is directly performed in the receiver by the condition. Confirm with *"Ok"* and continue with 3.2.1.35.

"Back" returns to the previous screen.

Initiator	
You have decided not to use an initiator.	
Back	Ok

3.2.1.29

Select the initiator (transmitter) which is to trigger the action in your receiver if the condition is fulfilled.

Initiator	
Select the transmitter you want to use.	
Back	Next

3.2.1 Setting up logic links

3.2.1.30

Select the room in which the desired transmitter (initiator) is located (in this case: study).

"Back" returns to the previous screen.

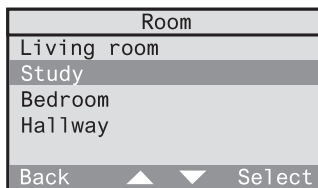

3.2.1.31

The following list contains only types of transmitters already existing in the selected room. Select first a transmitter type (in this case: hand transmitter).

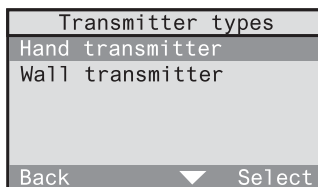

3.2.1.32

A list with the transmitters existing in the desired room (in this case: hand transmitters) appears. Select the transmitter that is to serve as initiator.

"Back" returns to the previous screen.

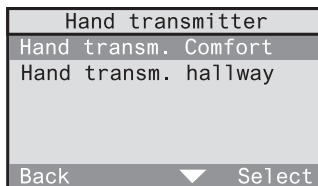

3.2.1.33

Select an available control element (in this case: channel key).

"Back" returns to the previous screen.

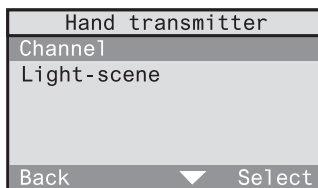

3.2.1.34

When a channel key of a hand transmitter is selected, a channel group selection is effected first (without illustration). The desired channel can be selected thereafter. For other control elements (e.g. light-scene) a corresponding selection is offered.

"Back" returns to the previous screen.

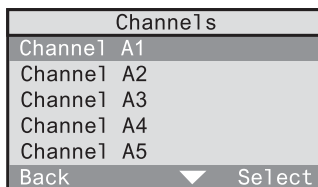

Selecting an action

When a presence detector, monitor or a smoke detector has been selected as the initiator (transmitter), the action to be performed can be freely chosen depending on the receiver.

Otherwise, the following relationships apply:

- If a specific receiver and a channel or light-scene key have been selected, no action can be chosen as the respective function (e.g. switching on / off, light-scene 3) is directly executed.
- If "All" was selected in the receiver types screen and if a channel key has been fixed as the initiator, no action can be chosen as the leaving / welcome function is directly executed.

3.2.1.35

Confirm the info text with "Next".

"Back" returns to the previous screen.

The screen displays a selection of possible actions or otherwise the info that no action can be chosen.

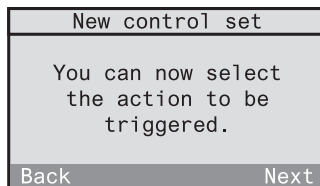

3.2.1.36

The control set for the selected radio control receiver is now defined. It is also possible to define further control sets for this receiver. In this case, confirm with "Yes". The definition of a new control sets begins again with screen 3.2.1.9. "No" returns to the menu.

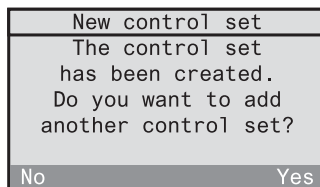

Changing logic links

To edit or to delete an existing logic link, read chapter 3.2.3 "Changing logic links" in the operating instructions.

3.2.2 Activating and deactivating logic links

The logic links stored in the radio control unit can be activated or deactivated in acc. with your requirements. To do so, proceed as follows:

3.2.2.1

Select "*Automatic mode*" in the main menu.

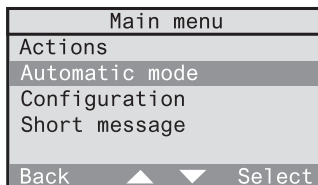

3.2.2.2

Select "*Logic links*" in the Automatic menu.

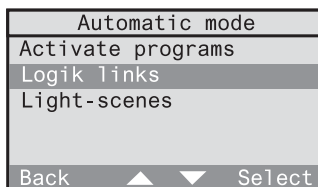

3.2.2.3

The list of stored logic links is displayed. Activated logic links are marked "✓", deactivated ones are marked "-". The status of the logic link can be changed by selecting the link with "*Select*".

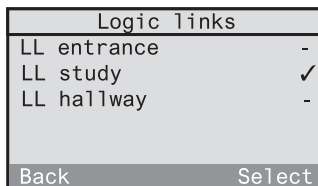

Important information



- A newly established logic link is activated by default.
- Several logic links may be active at the same time. The links are completely independent of each other.

3.2.3 Changing logic links

You can change existing logic links at any time to adapt them to your requirements. The changes mentioned below will be explained in greater detail on the following pages:

- Changing the name of a logic link Page 156
- Adding a new control set Page 157
- Deleting an existing control set Page 158
- Changing the receiver in the logic link Page 159
- Changing the time of the logic link Page 160
- Changing the condition (transmitter status) Page 160
- Changing the initiator (transmitter) Page 160
- Changing the action to be performed Page 160

Changing the name of a logic link

3.2.3.1

Select "*Configuration – Logic link*" in the menu. The list with all logic links stored is displayed. Select the logic link whose name is to be changed (in this case: Study).

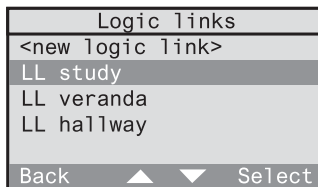

3.2.3.2

Select "*Change name*" in this menu.

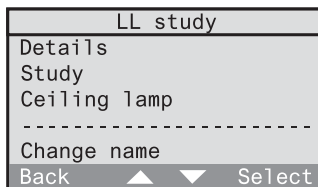

3.2.3.3

In this screen, the name of the logic link can be edited. For entering text, use the 12-key key-pad (cf. fold-out page (3)). "*Abc*" shifts between capital and small letters. "<->" deletes the last character. When you have entered a name, confirm with "*Ok*".

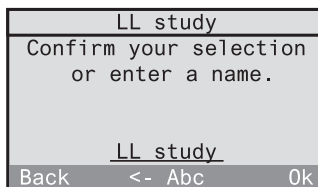

A brief press on "*Back*" returns to the previous screen or the next higher menu level.

A long press on "*Back*" returns to the standard display.

Adding a new control set

3.2.3.4

Select "*Configuration – Logic link*" in the menu. The list with all logic links stored is displayed. Select the logic link to which you want to add a new control set (in this case: Study).

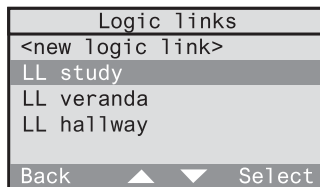

3.2.3.5

Select "*Details*" from the menu.

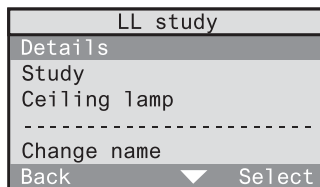

3.2.3.6

This screen shows a list of the actual control sets. Select *<New control set >* to add a new control set to the logic link.

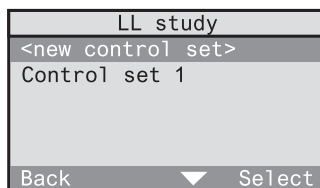

To add the new control set, proceed in acc. with the instructions of screens 3.2.1.9 to 3.2.1.34.

3.2.3 Changing logic links

Deleting an existing control set

3.2.3.7

Select "*Configuration – Logic links*" in the menu. The list with all logic links stored is displayed. Select the logic link in which you want to delete a control set (in this case: Study).

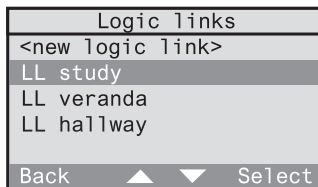

3.2.3.8

Select "*Details*" from the menu.

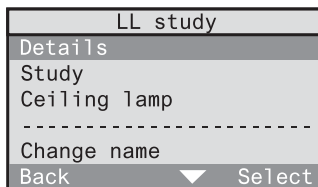

3.2.3.9

This screen shows a list of the actual control sets. Select the control set you want to remove (in this case: Control set 2).

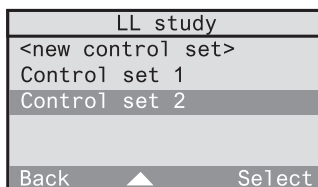

3.2.3.10

To delete the control set, select "*Delete*" at the end of the screen. Answer the subsequent confirmation request with "Yes".

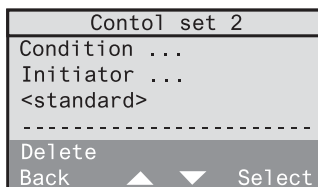

A brief press on "*Back*" returns to the previous screen or the next higher menu level.

A long press on "*Back*" returns to the standard display.

Changing the receiver in the logic link

You can change the receiver in an existing logic link. The new receiver may be located in the same room or in another room.



Important information

To ensure proper functioning of the logic link after the change, the new receiver must be of the same type as the old one (e.g. switching actuator). If this is not the case, it is recommended to set up a new logic link.

3.2.3.11

Select "*Configuration – Logic links*" in the menu. The list with all logic links stored is displayed. Select the logic link in which you want to change the receiver (in this case: Study).

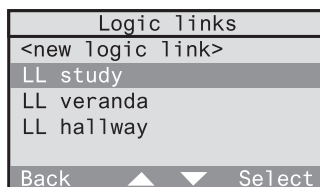

3.2.3.12

If the new receiver is located in another room, select the corresponding room (in this case: Study). At first, a list of all available rooms is displayed and then a list of the receivers of the same type (e.g. all switching actuators).

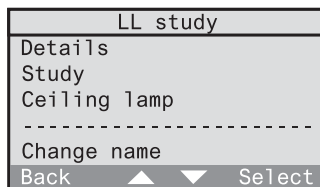

If the new receiver is located in the same room, select directly the old receiver (in this case: Ceiling lamp). The list of receivers of the same type available in this room is displayed.

A brief press on "*Back*" returns to the previous screen or the next higher menu level. A long press on "*Back*" returns to the standard display.

3.2.3 Changing logic links

Changing the time, condition (transmitter status), initiator (transmitter) or action to be performed

In an existing logic link, the time, the condition (transmitter status), the initiator (transmitter) and also the action to be performed can be changed.

3.2.3.13

Select "*Configuration – Logic link*" in the menu. The list with all logic links stored is displayed. Select the logic link in which you want to make changes (in this case: Study).

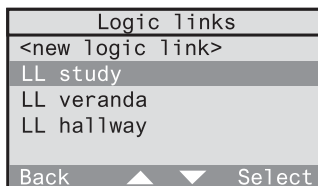

3.2.3.14

Select "*Details*" from the menu.

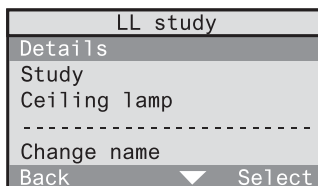

3.2.3.15

Select the control set you want to change (in this case: Control set 2) from the list of existing control sets.

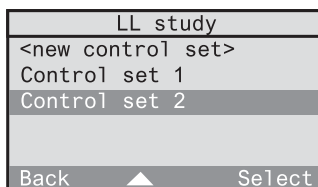

3.2.3.16

This screen shows a list of control set details. The following screens show the changes that can be made.

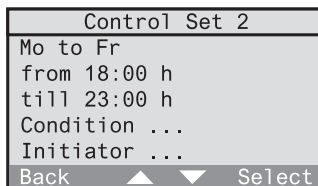

• Changing the weekdays

To change the weekday setting, select Weekdays (in this case: Mo to Fr) and follow the dialog instructions (cf. also 3.2.1.10 and 3.2.1.11).

• Changing the starting and ending time

To change the starting and ending time, select this setting and follow the dialog instructions (cf. also 3.2.1.13 resp. 3.2.1.14).

• Changing or deleting the condition (transmitter status)

3.2.3.17

Select "*Configuration*" in screen 3.2.3.16. A list showing the room, transmitter name, control element and state of the actual transmitter is displayed.

Condition	
Hallway	
Wall transmitter	
Channel 1	
On	

Back	Select

If you want to designate a new transmitter in another room as a condition, select the current room (in this case: Hallway). Follow the dialog instructions (cf. also 3.2.1.19 to 3.2.1.24).

If you want to designate a new transmitter in the same room as a condition, select the current transmitter (in this case: Wall transmitter). Follow the dialog instructions (cf. also 3.2.1.20 to 3.2.1.24).

If you only want to designate a new control element for the current transmitter as a condition, select the current control element (in this case channel 1). Follow the dialog instructions (cf. 3.2.1.23 to 3.2.1.24).

If you only want to change the status of the current transmitter, select the actual state (in this case: On). Follow the dialog instructions (cf. 3.2.1.24).

3.2.3 Changing logic links

You can also **delete** the complete condition. In this case, the control set is defined only by the weekday and the time of day already selected. To delete the condition, select "*Delete*" at the end of screen 3.2.3.17. Answer the subsequent confirmation request with "Yes".

Screen 3.2.3.16 indicates the status behind the term "Condition" by means of the following signs:

- no condition existing
- ... condition existing

• Changing the initiator (transmitter)

3.2.3.18

Select "*Initiator*" in screen 3.2.3.16. An overview showing the room, transmitter name and control element of the current initiator is displayed.

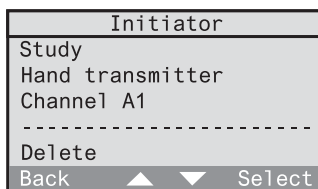

If you want to designate a new transmitter in another room as an initiator, select the current room (in this case: Study). Follow the dialog instructions (cf. also 3.2.1.29 to 3.2.1.33).

If you want to designate a new transmitter in the same room as an initiator, select the current transmitter (in this case: Hand transmitter). Follow the dialog instructions (cf. also 3.2.1.30 to 3.2.1.33)

If you only want to designate a new control element for the current transmitter as a condition, select the current control element (in this case: channel A1). Follow the dialog instructions (cf. 3.2.1.32 to 3.2.1.33).

You can also **delete** the complete initiator. In this case, the action performed by the receiver is directly controlled by the condition. To delete the initiator, select "*Delete*" at the end of screen 3.2.3.18. Answer the subsequent confirmation request with "Yes".

Screen 3.2.3.16 indicates the status behind the term "Initiator" by means of the following signs:

- no initiator existing
- ... initiator existing

- **Changing the action to be performed**

3.2.3.19

If a presence detector or monitor is selected as an initiator, the action to be performed can be changed as well. Select the current action (in this case: On). A list of alternative actions is displayed.

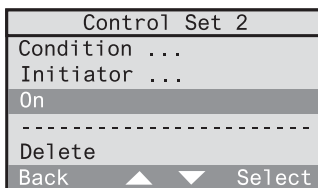

3.2.3.20

If another transmitter is designated as initiator, no action can be chosen, as the activated function will be executed (e.g. short key-press ⇒ switching).

In the detailed list, this is marked as "<standard>".

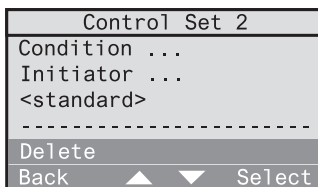

3.2.4 Deleting logic links

Logic links can be deleted completely. To do so, proceed as follows:

3.2.4.1

Select "*Configuration – Logic links*" in the menu. The list with all logic links stored is displayed. Select the logic link you want to delete (in this case: Study).

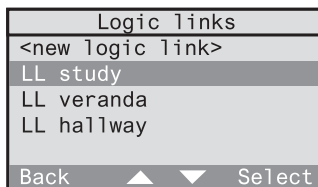

3.2.4.2

Select "*Delete*" at the end of the menu.

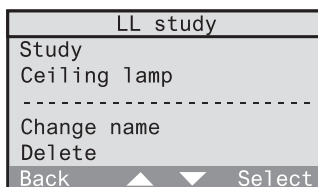

3.2.4.3

To delete the logic link, answer the confirmation request with "Yes". "No" returns to the previous screen.

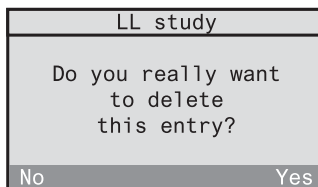

A brief press on "*Back*" returns to the previous screen or the next higher menu level. A long press on "*Back*" returns to the standard display.

3.3 Working with light-scenes

All radio control receivers programmed into the radio control unit can accommodate 5 light-scenes.

Lighting actuators (dimming and switching actuators) can be programmed for a specific brightness level (e.g. 70 %) or switching state (e.g. On) in a light-scene.

Shutter actuators can be programmed for a limit stop position (completely up or completely down) in a light-scene.

Light-scenes can be stored and recalled for all the rooms or for each room individually. They can moreover be stored and recalled completely or separately for lighting actuators (dimming and switching actuators) or for shutter actuators.

Application examples:

In your dining room, you have a dimmable ceiling lamp and a dimmable reading lamp. The room also has two shutters (shutter facing north and shutter facing south).

When the TV is running, the ceiling lamp is to be at 50% brightness and the reading lamp at approximately 30% brightness. The shutter facing south is lowered whereas the shutter facing north is still up.

These settings and positions can be stored completely or separately for lighting and for shutters in the radio control unit in a light-scene which can be recalled or also modified at any time.

3.3 Working with light-scenes

In addition, the light-scenes labelled "All-On" and "All-Off" are also available for each room. These scenes are predefined for lighting purposes. When recalled, all lighting actuators (switching and dimming actuators) in a room are switched on or off. These scenes can be modified, if necessary.

The 5 light-scenes and also "All-On" and "All-Off" can be programmed with shutter actuators only for the limit-stop positions (completely up or completely down).



Important information:

The values for light-scenes 1-5 and the All-On and All-Off functions stored and recalled via the radio control unit are the same as those recalled from or stored in another radio control transmitter (e.g. hand transmitter).

3.3.1 Storing and changing light-scenes

A light-scene or also an "All-On" or "All-Off function" can be changed and stored completely or separately as desired for individual rooms. In addition, you can also change and store only the settings for lighting actuators or shutter actuators.



Information for shutters

With shutter actuators, only the limit-stop positions of the shutter (completely up or completely down) can be stored in light-scenes. If the shutter is not in its limit-stop position or on its way to this position during storing of a light-scene, the corresponding shutter cannot be stored in this light-scene.



Information for 1-channel UP switching actuator

If a 1-channel UP radio switching actuator which is not labelled at least R2 (see device rating plate) is used in your radio control system, note the following special reactions:

If light-scenes are stored in this switching actuator via the radio control unit, the actuator **always** saves the "Off" state.

To save the "On" state for the light-scene, the scene must be stored with another radio control transmitter (e.g. radio control hand transmitter). Read the operating instructions of the corresponding radio control transmitter.

3.3.1 Storing and changing light-scenes

Procedure

Start by setting the light-scene for lighting actuators and/or shutter actuators in the desired area (room or all rooms) in accordance with your requirements.

3.3.1.1

Select "*Configuration – Save light-scene*" in the menu.

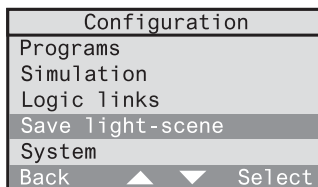

3.3.1.2

A list with the available rooms is displayed. Select the room for which you want to change and store a light-scene. The selection of "*Central function*" permits changing and storing a light-scene for more than one room.

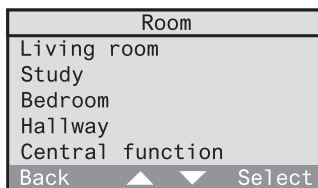

3.3.1.3

Select now whether you want to change and store the light-scene for all actuators or only for the lighting or the shutter actuators.

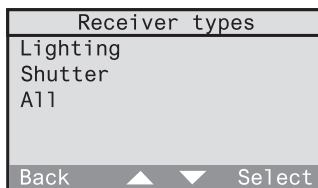

3.3.1.4

Select finally the light-scene you want to store. The list offers light-scenes 1-5, All-On and All-Off.

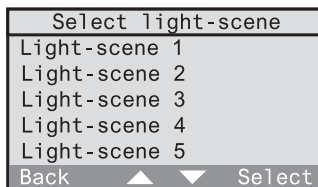

3.3.1 Storing and changing light-scenes

3.3.1.5

Before storing the light-scene make sure once again that the corresponding actuators are adjusted as desired. Then, confirm with "Ok".

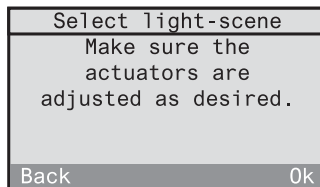

A short tone can be heard and the light-scene is stored. This will take you back to screen 3.3.1.3 for changing and storing further light-scenes in the selected area.

A brief press on "*Back*" returns to the previous screen or the next higher menu level. A long press on "*Back*" returns to the standard display.

3.3.2 Recalling light-scenes

All stored light-scenes (including All-On and All-Off) can be recalled for each room and separately for lighting and shutter via the menu or user-defined hotkeys on the keypad.

Recalling light-scenes via the menu

To recall light-scenes via the menu, select first *"Automatic – Light-scenes"* in the menu.

3.3.2.1

A list with available rooms is displayed. Select the room in which you want to recall a light-scene. Select *"Central function"* if you want to recall a light-scene for more than room.

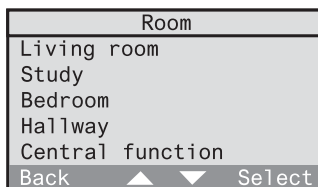

3.3.2.2

Select now whether you want to recall the light-scene for all actuators or for the lighting or the shutter actuators only.

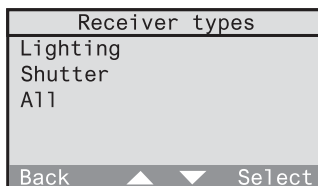

3.3.2.3

Select finally the light-scene you want to recall. The list offers light-scenes 1-5, All-On and All-Off.

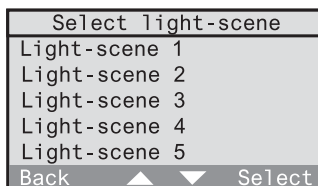

3.3.2 Recalling light-scenes

The light-scene is recalled and you are taken back to screen 3.3.2.2 for recalling further light-scenes in the selected area.

A brief press on "*Back*" returns to the previous screen or the next higher menu level. A long press on "*Back*" returns to the standard display.

Recalling light-scenes via hotkeys

Often used light-scenes can be programmed on one of the numerical keys 0-9 of keypad (3) and then be recalled directly via hotkey.

3.3.2.4

To program a light-scene on a numerical key, mark first the light-scene as shown in screens 3.3.2.1 to 3.3.2.3 (in this case: Light-scene 3). Depress the desired numerical key (ca. 1 s) until a short tone is heard. The key is now programmed.

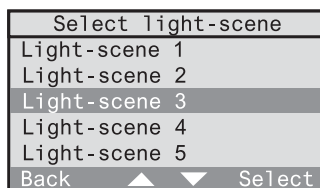

To recall a light-scene by user-defined hotkey, the radio control unit must display the standard screen (see fold-out page). For recalling the light-scene, depress the desired numerical key briefly.

4.0 Manual operation

A programmed radio control receiver can also be addressed via the menu or directly by pressing a hotkey on the keypad independently of running programs. The receiver can also be made to execute an action.

Controlling a receiver via the menu

To control a programmed radio control receiver via the menu, select first "Actions" in the menu.

4.0.1

The next screen lists the rooms where radio control receivers are installed. Select the room in which you want to control a radio receiver (in this case: Study). To control receivers of the same type also in other rooms, select "Central function".

Room	
Living room	
Study	
Bedroom	
Hallway	
Central function	
Back	▲ ▼ Select

4.0.2

A list showing the receiver types installed in the selected room is displayed. Select the receiver type you want operate (in this case: dimming actuator). The selection of "All" permits calling up directly the Returning (welcome) / Leaving function.

Receiver types	
Dimming actuator	
Switching actuator	
Push-button actuator	
Shutter actuator	
All	
Back	▼ Select

4.0.3

Select the desired receiver from the list. With dimming, switching or push-button actuators you are always offered the "All dimmers & switches" option.

Dimming actuator	
All dimmers & switches	
Ceiling lamp	
Reading lamp	
Back	▲ ▼ Select

4.0.4

The possible actions are displayed as a function of the previously selected receiver type (in this case: dimming actuator). Select the desired action. The following description explains all possible actions and their combination with receiver types.

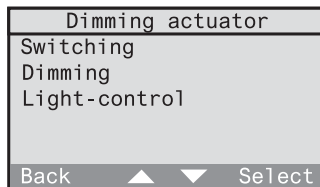

Description of actions



Important information:

If a special function is programmed for the receiver, the execution of the action described may be followed by the execution of the special function.

Read also chapter 5.4 "Special functions".

Switching (only with: switching and dimming actuators)

Switching on / off

The selected receiver is switched on or off.

Dimming (only with: dimming actuators)**Dimming level**

The actuator can be adjusted to a specific dimming level. Adjust the dimming level directly with the numerical keys or with "▲" and "▼".

When "Ok" is pressed once, the corresponding receiver switches to the selected dimming level for approval.

When "Ok" is pressed a second time, the dimming level is stored and the screen disappears. "Back" returns to the previous screen.

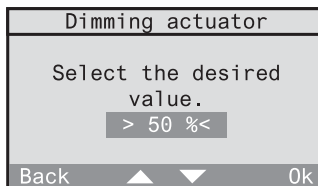
**Momentary contact function (only with: push-button actuators)****Actuate**

The selected push-button actuator transmits a short pulse.

Shutter (only with: shutter actuators)

Limit-stop position – top / bottom

The selected shutter is moved into the upper or lower limit-stop position.

Movement - position

The selected shutter can be moved into a specific position, if the shutter moving time has been defined beforehand (cf. chapter 2.3). 0 % corresponds to "completely up" and 100 % to "completely down". Adjust the shutter position directly with the numerical keys or with "▲" and "▼".

When "Ok" is pressed once, the corresponding actuator moves the shutter to the selected position for approval.

When "Ok" is pressed a second time, the position is stored and the screen disappears. "Back" returns to the previous screen.

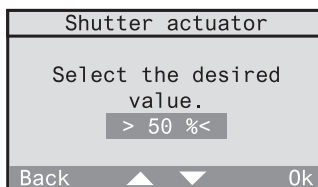

Presence (only with: All)

Leaving

The last brightness values of the lighting and the shutter end positions are stored before the All-Off telegram is transmitted.

Returning

Depending on the defined special functions (delay, action) of the radio-control receiver, 3 types of reactions are available:

- **Delay: 0 min; action: <none>**

The value stored before leaving is restored on returning. Observe also the information in chapter 5.4.

- **Delay: 0 min; action: defined**

The defined action is performed on return.

- **Delay: > 0 min; action: defined**

At first, the value stored before leaving is restored on returning. The defined action is then performed at the end of the delay.

Read also chapter 5.2 "The leaving / returning function" in the operating instructions.

Light control (only with: switching and dimming actuators)

Light control on /off

If a radio-control presence detector has been programmed into the receiver, the light control can be activated or deactivated here. Any other action transmitted by the radio control unit deactivates an active light control.

Adopting the lux value

If a radio presence detector has been programmed into the selected receiver, the actual brightness value can be stored in the actuator as brightness reference value (lux value) for the light control function.

Controlling receivers via hotkey

Often needed actions can be programmed on one of the numerical keys 0-9 of keypad (3) for direct recall via hotkey. The following two actions cannot be activated by hotkey as they both need a percentage as input:

- dimming – dimming level
- shutter - movement - position

To program an action on a numerical key, select first the action in screens 4.0.1 to 4.0.4 and mark them. Then, depress the desired numerical key (ca. 1 s) until a short tone is heard.

Programming of the key is terminated.

To recall an action by user-defined hotkey, the radio control unit must display the standard screen (see fold-out page). For recalling the action, depress the desired numerical key briefly.



Important information:

You can also control your radio receivers directly with radio transmitters independent of the radio control unit. To do so, the transmitter must have been programmed beforehand into the corresponding receivers (read the operating instructions of the corresponding product).

5.0 Extra functions

Besides automatic and manual operation, the radio control unit has other functions and features making everyday life easier for you, such as:

- 5.1 The short message service
- 5.2 The returning / leaving function
- 5.3 The master key
- 5.4. The special functions (delay, action)

5.1 Using short messages

The radio control unit offers the possibility of leaving short messages. The short message can consist of approximately 250 characters. When a short message has been left in the unit, the short message symbol (15) is displayed in the standard screen. No symbol means that no message has been left in the unit.

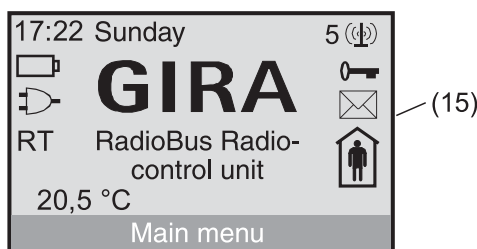

Fig. 5.a: Short message symbol

Writing a short message

If a new short message is to be written, the short message memory of the radio control unit must be empty. An old message still in the memory must be deleted first (see: "Deleting a short message").

5.1.1

Select "*Short message*" in the main menu. "*Back*" returns to the standard screen.

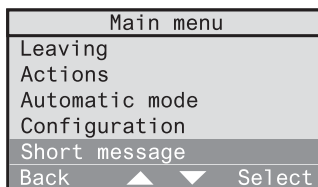

5.1.2

If the short message memory is empty, you can now select "*New message*". Otherwise, the old message must first be deleted (see: "Deleting a short message"). "*Back*" returns to the previous screen.

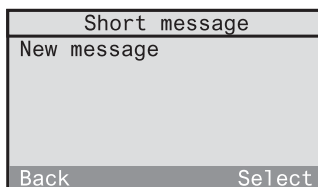

5.1.3

In this screen, a short message can be edited. For entering text, see chapter "1.3.3 Entering text". Confirm with "*Ok*". "*Back*" returns to the previous screen.

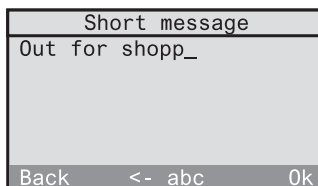

5.1.4

The menu for changing or deleting the newly established message is displayed. Read "Changing or deleting a short message". Pressing "*Back*" confirms the new message and returns to the menu.

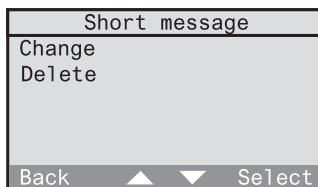

Changing or deleting a short message

To delete or to change an existing short message, select "*Short message*" in the menu.

5.1.5

The text of the short message is displayed. Pressing "*Next*" displays a menu for changing or deleting of the message. "*Back*" returns to the menu.

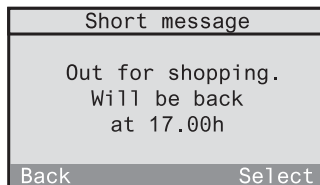

5.1.6

Select "*Change*" to edit the message. Select "*Delete*" and answer the confirmation request with "*Yes*" to delete the message. "*Back*" returns to the menu.

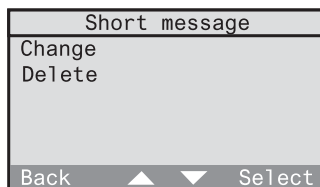

Important information

The master key (9) can optionally be programmed for the short message menu or for the returning / leaving function for direct access to the respective function just by pressing the master key. Read chapter 5.3 "The master key".

5.2 The returning (welcome) / leaving function

The last brightness values of the lighting and the shutter end positions are stored on activation of the 'Leaving' function before the radio control unit transmits the All-Off telegram.

Depending on the predefined special functions, the returning (welcome) function leads to the following reactions (see chapter 5.4):

① **Delay: 0 min; action: <none>**

The value stored before leaving is restored on returning.

② **Delay: 0 min; action: defined**

The defined action is performed on return.

③ **Delay: > 0 min; action: defined**

At first, the value stored before leaving is restored on returning. The defined action is then performed at the end of the delay.



Technical information 1-channel flush-mounted switching actuator

If a 1-channel flush-mounted switching actuator which is not at least version R2 is used in your radio control system (see device rating plate), note the following special behaviour:

On recalling of the leaving function, this switching actuator **always** saves the "Off" status.

In special function setting ①, this actuator would therefore remain off on activation of the returning function.

If you prefer the "On" state instead, it is recommended to select special function setting , with
delay = 0 min; action: on

The switching actuator will then **always** switch on when the returning function is activated.

5.2 The returning (welcome) / leaving function

The current status of the radio control unit is indicated on display by symbol (16):



Presence



Absence

If you have selected a presence simulation program (cf. chapter 3.1.5), this program will be activated on "leaving" the house. The switching times will be varied at random by ± 15 minutes.

All other activated programs will be executed independently of the returning / leaving function.

5.2.1

Select "Leaving" in the main menu when you leave your house. The corresponding function will be executed and the absence symbol is displayed in the standard screen. The menu changes automatically to "Welcome".

Select "Welcome" when you are back in the house.

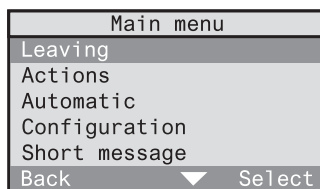

Important information

The master key (9) can optionally be programmed for the returning (welcome) / leaving function or the short message menu for direct access to the respective function via the master key. Read chapter 5.3 "The master key"

The returning (welcome) / leaving function can also be activated from a transmitter. Read chapter 3.2 "Working with logic links".

5.3 The master key

The master key (9) can optionally be programmed for one of the following functions:

- **No function**

The master key has no function.

- **Short message**

The master key can be used to recall, write, change or delete a short message. Read chapter 5.1 "Using short messages".

- **Returning / leaving function**

The master key can be used to activate alternately the returning (welcome) / leaving function. Read chapter 5.2 "The returning / leaving function".

5.3.1

To program the master key for a specific function, select "*Configuration -System – Master key*" in the menu.

"*Back*" returns to the next higher menu level.

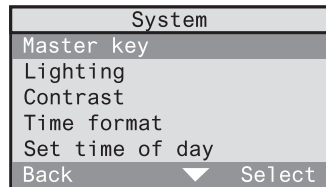

5.3.2

The possible functions for the master key are displayed. Move the bar to the function you want to activate directly with the master key and confirm your selection with "*Select*". The function is now programmed and the screen returns to the next higher level.

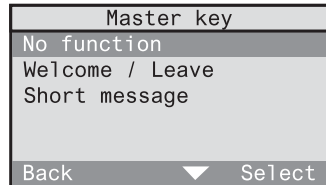

5.4 Special functions (delay, action)

If required, each radio control receiver can be programmed for the special functions 'delay' and 'action'. Three different settings are available:

① **Delay: 0 min; action: <none>**

This is the preset configuration for each receiver, i.e. the respective receiver does not execute any special functions. When the returning function ('welcome' function) is called up, the value stored before leaving will be restored.

② **Delay: 0 min; action: defined**

On activation of the returning function, the respective receiver immediately executes the function defined here.

Example: switching actuator; delay: 0 min; action: on

⇒ On activation of the returning function, the switching actuator switches on.

③ **Delay: > 0 min; action: defined**

On reception of a programmed radio telegram from the radio control unit, the respective receiver executes first the corresponding action. After the defined delay, the receiver executes the action defined here under special functions.

Example: switching actuator; delay: 1 min; action: off

In addition, a logic link is defined for this switching actuator, in which a radio control detector as initiator is to switch on the radio control receiver.

⇒ On reception of a detector telegram via the radio control unit, the switching actuator is first switched on and then off again after 1 min.

⇒ On activation of the returning function, the value stored before leaving is restored. After the delay of 1 min has elapsed, the actuator switches off.



Technical information 1-channel flush-mounted switching actuator

If a 1-channel flush-mounted switching actuator which is not at least version R2 is used in your radio control system (see device rating plate), note the following special behaviour:

On activation of the leaving function or on storing of a light-scene via the radio control unit, this switching actuator **always** saves the "Off" status.

In special function setting ①, this actuator would therefore remain off on activation of the returning function.

If you prefer the "On" state instead, it is recommended to select special function setting , with
delay = 0 min; action: on

The switching actuator will then **always** switch on when the returning function is activated.

If light-scenes are stored with this actuator via the radio control unit, the device will always save the "Off" state. To save the "On" state for the light-scene, the scene must be stored with another radio control transmitter (e.g. radio control hand transmitter).

Setting of delays and actions for receivers

To set the delay time and the action for a specific receiver, select *"Configuration - Components - Overview"* from the menu.

5.4.1

Select the room where the desired receiver is located (in this case: Study).

"Back" returns to the previous screen.

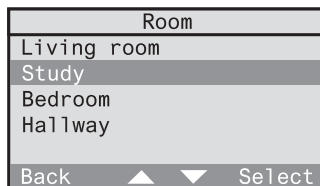

5.4.2

Select *"receiver"* in the menu.

"Back" returns to the previous screen.

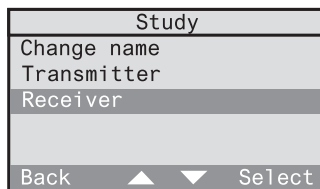

5.4.3

The list of receiver types is displayed.

Receivers above the line "---" are receiver types actually existing in the selected room. Below the line, all other receiver types are listed.

Select the receiver type above the line for which the delay and the action are to be set (in this case: Switching actuator).

"Back" returns to the previous screen.

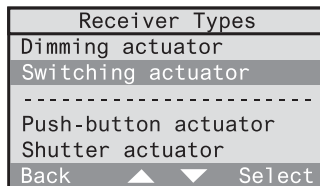

5.4.4

A list with the switching actuators existing in the selected room is displayed. Select the switching actuator for which you want to set the delay and the action (in this case: Desk).

"Back" returns to the previous screen.

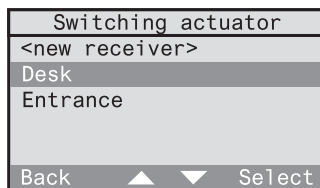

5.4 Special functions (delay, action)

5.4.5

Select here "*Special functions*".
"*Back*" returns to the previous screen.

Desk	
Change name	
Assign room	
Special functions	
Delete	
Back	▲ ▼ Select

5.4.6

Select "*Delay*" to set a delay between 0 and 240 min (interval 1 min).
Select "*Action*" to program an action into the receiver.
"*Back*" stores the adjusted values.

Desk	
Delay:	
0min	
Action	
<no function>	
Back	▼ Select

Actions: further reading



The meaning of individual actions is explained in the present operating instructions in chapter 3.1.1 "Setting up time-controlled programs" on page 115.

6.0 Project saving

The radio control unit manual is supplied with a radio control unit Mastercard for saving project data.

All customer-specific project data can be saved on this card and, if needed, also be reloaded into the unit.

The radio control unit Mastercard is detected automatically by the radio control unit when the standard screen is displayed. The card is inserted with the micro-chip ahead into the chip-card reader (4) as shown in fig. 6.a.

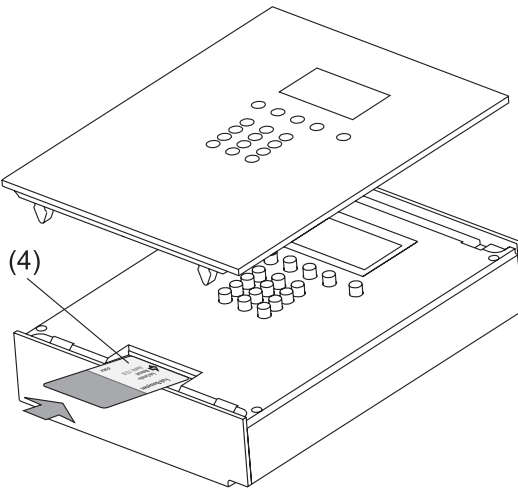

Fig. 6.a: Inserting the radio control unit Mastercard



Important information

If the inserted radio control unit Mastercard is not the card issued with your radio control unit, a corresponding information will be displayed. After confirming the info, it is nevertheless possible to load project data from and to save project data back onto this card.

Glass front cover

To remove the front cover, cf. chapter 1.4 "Removal of the front cover" of the fitting and start-up instructions.

6.1 Saving the project

To save the current project data, insert the radio control unit Mastercard into the chip-card reader as shown in chapter 6.0.

6.1.1

After identification of the card, the radio control unit automatically displays the master card menu. Select "Save project".

"Back" returns to the standard screen.

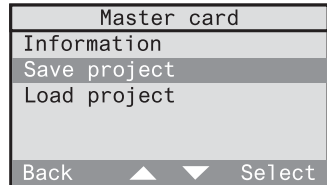

6.1.2

If you want to save the current project data, confirm with "Yes".

Important:

Any existing project data on the radio control unit Mastercard will be overwritten.

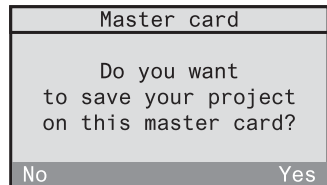

After successful saving of the data, the radio control unit returns to the menu and the radio control unit Mastercard can be removed.

6.2 Loading the project

To load project data from an radio control unit Mastercard, insert the card into the chip-card reader as shown in fig. 6.0.

6.2.1

After identification of the card, the radio control unit automatically displays the master card menu. Select *"Load project"*.

"Back" returns to the standard screen.

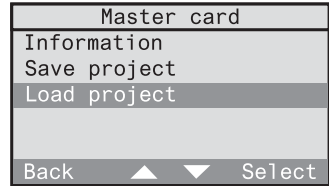

6.2.2

If you want to load the project data from the inserted card, confirm with *"Yes"*.

Important:

Any existing project data in the radio control unit will be overwritten.

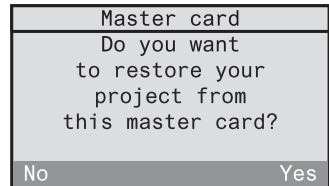

After successful loading of the data, the radio control unit returns to the menu and the radio control unit Mastercard can be removed.

7.0 Transmitter diagnosis

Your radio control unit offers the possibility to display the room, name and battery condition of programmed transmitters for diagnosis purposes.

7.0.1

Select "*Configuration - Components – Transmitter test*" in the menu.
"*Back*" returns to the next higher menu level.

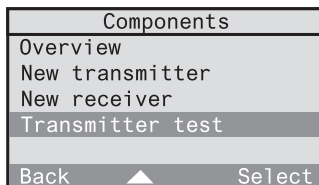

7.0.2

Send a radio telegram from a programmed transmitter. "*Back*" returns to the previous screen.

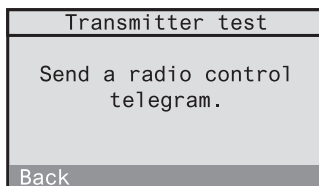

7.0.3

If the transmitter is a programmed one, the radio control unit displays the following data for the control transmitter:

- room
- transmitter type
- transmitter name
- battery condition

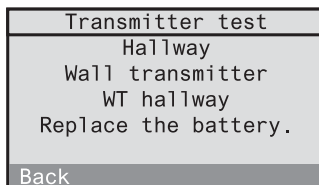



No battery status message will be displayed, if the batteries are still in good condition.

Manual

Annex

A) Troubleshooting and answers to problems

Overview

- a) Plug symbol (20) flashing 
- b) Battery symbol (21) flashing or on 
- c) Keypad does not react 
- d) PIN number of configuration menu access lock forgotten.
- e) A program does not work.
- f) On recalling of light-scenes or of the returning function, a 1-channel flush-mounted switching actuator remains always off although a different brightness should be in memory.
- g) After actuation of All-Off or triggering of the leaving function, one or more actuators switch on again.
- h) A logic link shows no reaction.
- i) Logic links do not respond to a battery-operated transmitter (e.g. hand or wall transmitter)
- j) Delays occurring between actuation of transmitter and actual execution of action in actuator (receiver).
- k) Display too dark or too bright.

a) Plug symbol (20) flashing 

The 230 V supply is failing or interrupted. Check that the mains supply cord is connected properly and that the corresponding fuse is OK.

b) Battery symbol (21) flashing or on 

The batteries in the unit are weak (symbol on) and should be replaced soon. A flashing symbol means that proper operation in the event of mains failure is no longer ensured. The batteries should be replaced immediately.

c) Keypad does not react 

Check whether the key-lock function is active. Key-lock is indicated by key symbol (14) in the standard screen. To set or to release the key-lock, press the  key for 1 s in the standard screen.

d) PIN number of configuration menu access lock forgotten

Even if you have forgotten the PIN number for the configuration menu, it is still possible to get access to the menu in spite of the active access lock. To get access, insert a valid radio control unit Mastercard into the chip-card reader when calling up the menu. The configuration menu is then accessible and you should immediately change the PIN or set it to '0'.

e) A program does not work

Check whether the program is activated. Read chapter 3.1.2 "Activating and deactivating programs" in the operating instructions.

- f) On recalling of light-scenes or of the returning function, a 1-channel flush-mounted switching actuator remains always off although a different brightness should be in memory.**

Light-scene: Note the info concerning the 1-channel flush-mounted switching actuator in chapter 3.3.1 "Storing and changing of light-scenes" in the operating instructions.

Returning (welcome) function: Note the info concerning the 1-channel flush-mounted switching actuator in chapter 5.2 "The returning / leaving function" in the operating instructions.

- g) After actuation of All-Off or triggering of the leaving function, one or more actuators switch on again.**

If this is not desired (e.g. as emergency lighting) check the special functions assigned to the actuators concerned. Read chapter 5.4. "Special functions" in the operating instructions. If a delay is preset for these actuators and if an action (e.g switching on) is defined, set delay to "0 min" and action to "<no function>".

- h) A logic link shows no reaction**

Check whether the logic link is activated. Read chapter 3.2.2 "Activating and deactivating logic links" in the operating instructions. Check also that the defined time (day and time of day) are OK and that a predefined condition, if any, is fulfilled.

- i) Logic links do not respond to a battery-operated transmitter (e.g. hand or wall transmitter)**

Check out first the solutions offered under (h). Then, check the transmitter batteries for condition by performing a transmitter diagnosis. Read chapter 7.0 "Transmitter diagnosis" in the operating instructions.

j) Delays occurring between actuation of transmitter and actual execution of action in actuator (receiver).

If an external repeater is used to improve the transmitting range, this device must have been programmed into the radio control unit. Repeaters may cause time delays.

If no external repeater is installed, no such device must be programmed in the unit. Read also chapters 2.2 and 4.0 "Repeater functions" in the operating instructions.

k) Display too dark or too bright

Readjust the contrast in the "Configuration - System - Contrast" menu.

The contrast can also be adjusted by pressing the  key together with function key 2 for more contrast and together with function key 3 for less contrast.

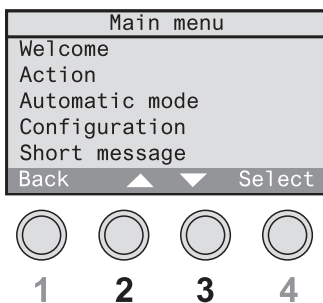



Fig. A1: Function keys 2 & 3

B) Serial numbers and versions

The serial numbers and version info for your radio control unit can be found in the menu under *"Configuration - System - Information"*.

Note the numbers here to have them available in case the unit needs servicing:

1:	*	_____	_____	*
2:	*	_____		*
3:	*	_____	*	
4:	*	_____	_____	*
5:	*	_____	_____	*
6:	*	_____	_____	*
7:	*	_____	_____	*



Important

The field marked in grey  contains the software version number

C) Technical data

Rated voltage:	AC 230 V ~, 50/60 Hz
Batteries:	5 x Micro, AAA 1,5 V, LR 03
Ambient temperature:	0 ... + 40 °C
Storage / transport temperature:	-12 ... + 65 °C
Transmit frequency:	433.42 MHz, ASK
Transmitting range:	max. 100 m (in free space)
Software category:	A
Type of protection:	IP 20
Safety class:	II
Dimensions (H x W x D)	240 x 182 x 52 mm



Technical specifications subject to change

D) Acceptance of guarantee

We accept the guarantee in accordance with the corresponding legal provisions.

Please return the unit postage paid to our central service department giving a brief description of the fault:

Gira
Giersiepen GmbH & Co. KG
Service Center
Dahlienstraße 12
D-42461 Radevormwald
Federal Republic of Germany

 The -sign is a free trade sign addressed exclusively to the authorities and does not include any warranty of any properties.

Main menu structure

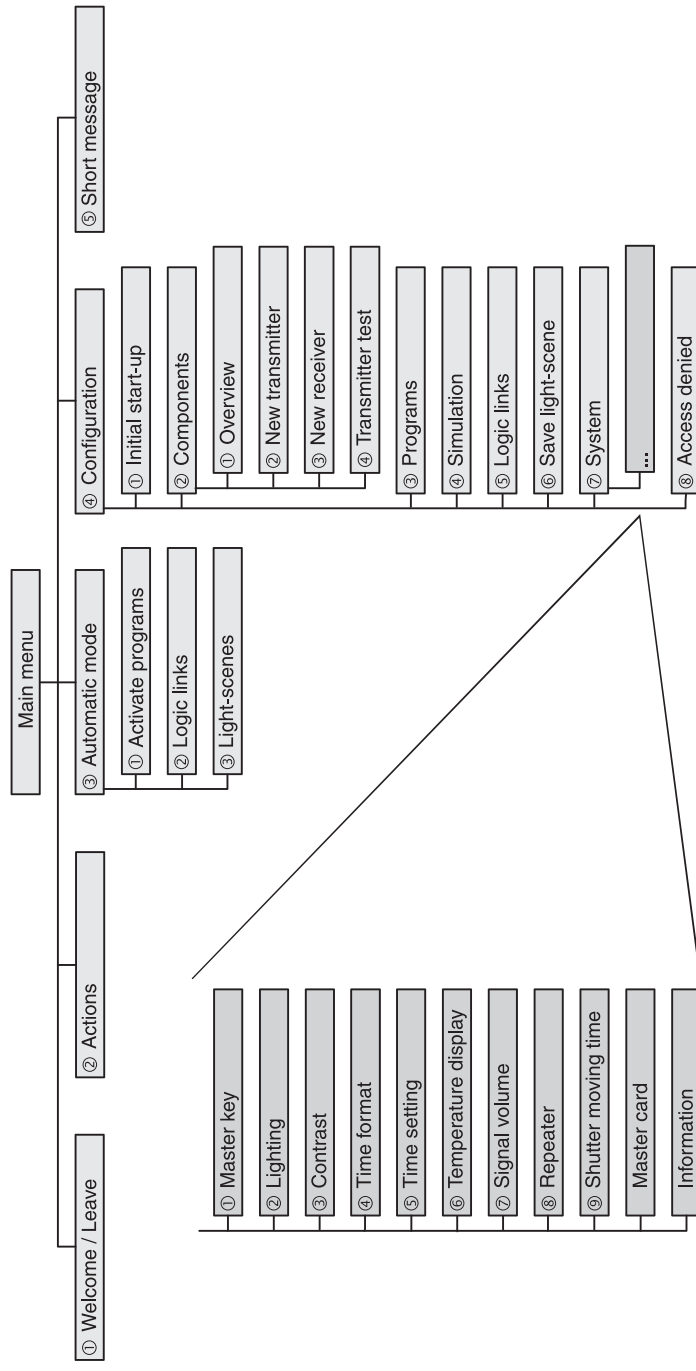

The numbers before the menu items correspond to the numbers on the keypad for quick selection of menus. To go to transmitter test, for instance, press ④, ② and ④ in sequence.

GIRA

GIRA
Giersiepen GmbH & Co. KG

Postfach 12 20
D-42461 Radevormwald

Telefon: 0 21 95 / 602-0
Telefax: 0 21 95 / 602 339
Internet: www.gira.de
E-mail: info@gira.de



Supplement to Manual on
Heating Control

Radio Controller
0358 18

GIRA

This manual provides you with information on the latest "Heating control" software update for the radio controller. This latest change is not yet contained in the radio controller manual. You can request the revised manual from us from November 2005 or download it on the Internet at www.gira.de.

Heating Control

The motor valve drives of your heating can be controlled both without and with room temperature sensors via the radio controller.

In both cases the radio controller specifies temperature setpoints via time-controlled programs, links and in the manual mode for the motor valve drives. The respective last value sent applies.

- **Time-controlled programs**

Temperature setpoints are sent to selected motor valve drives at specified times and evaluated there.

- **Links**

With radio transmitters (e.g. hand-held transmitters, wall transmitters etc.) you can have the radio controller send temperature setpoints to the motor valve drives.

- **Manual operation**

In the "Action menu" of the Radio controllers you can set or change temperature setpoints for your motor valve drives. In addition, the Party function or frost protection can also be selected.

The related actual temperature values are delivered by the motor valve drives, the room temperature sensors or the radio controller depending on the setting. This setting is located in the configuration menu (see "Special functions for motor valve drives").

The following additional functions offer you convenience for heating control with the radio controller:

Holiday

When the Holiday function is activated, a temperature setpoint you have defined is permanently set for a certain period (1 to 31 days), i.e. it is not overwritten by any other setpoint (e.g. from a time-controlled program).

The Holiday function ends after the set period ends or through manual deactivation. The first day of the Holiday function is the day on which the Holiday function is activated.

The Holiday function can refer to your entire house (central function), to certain rooms or to individual motor valve drives.

You can activate and deactivate the Holiday function in the "Automatic menu".

Frost Protection

When the Frost Protection function is activated, a temperature setpoint you have defined (default: 15 °C) is permanently set, i.e. it is not overwritten by any other setpoint (e.g. from a time-controlled program). The Frost Protection function must be ended by switching it off manually. It is practical if you are away from home for more than 31 days. Otherwise it is advisable to use the Holiday function.

The Frost Protection function can be activated or deactivated in the "Actions menu", via "Links" or via "Programs".

Party

When the Party function is activated, a temperature setpoint you have defined is permanently set for a certain time (1, 2, 3 or 4 hrs.), i.e. it is not overwritten by any other setpoint (e.g. from a time-controlled program).

The Party function ends after the set time ends or through manual switch-off. You can activate or deactivate the Party function in the "Actions menu" or via "Links".

Assigning a Motor Valve Drive

When assigning a motor valve drive, the radio controller expects a confirmation from the valve drive. These are cyclically sent by the valve drive as soon as it is in the programming mode.

Special Functions for Motor Valve Drives

You can define the following special functions for your motor valve drives in the menu "Configuration - Components - Overview - <Room> - Receiver - Valve Drive".

- Heating circuit distributor
- Basic temperature
- Departing temperature
- Actual value sensor
- Status

Heating circuit distributor

If the motor valve drive is operated on a heating circuit distributor (e.g. floor heating), you should set it here. As a result, the temperature setpoint and actual value are updated every 3 minutes instead of every 10 minutes.

Basic temperature

Set a basic temperature here between 5 °C and 30 °C (increment: 0.5 K). If you do not specify a value, then the basic temperature is set to 18 °C.

The related motor valve drive sets this basic temperature if no other temperature setpoint is available to it (e.g. following initialisation).

Departing temperature

Set the temperature here which is to be set when the Departing function is activated. A temperature range from 5 °C to 30 °C with increments of 0.5 K is available.

If you do not wish a change to be made when departing, select "No action" here.

Actual value sensor

So that a motor valve drive can carry out control with a temperature setpoint, it requires an actual temperature value. The motor valve drive provides itself with this. However, it can also be provided by a room temperature sensor or the radio controller as an alternative.

Select a corresponding actual value sensor from the list specified here. The setting "Sensor valve drive" means that the respective motor valve drive uses its own actual temperature value for control.

Status

In the Status screen you can view the current temperature setpoint and actual value of the respective motor valve drive for information purposes. If a "-" is shown for the actual value instead of a temperature, then "Sensor valve drive" has been selected as the actual value sensor. In this case the motor valve drive uses its own actual temperature valve for control.

In addition, the status of the Party, Frost Protection and Holiday functions, as well as of the heating circuit distributor is also shown in the status screen.

Here the symbols have the following meaning: ✓ = Function is activated

– = Function is deactivated

Creating Time-Controlled Programs

With a motor valve drive as a receiver (link), the following actions can be selected independently of the selected triggering device: Setpoint, Change setpoint, Party and Frost Protection.

Presence (only with: All)

- **Departing**

With motor valve drives, the temperature defined for "Departing" is set or no action is carried out (menu: *Configuration - Components - Overview - Receiver - <Valve drive list> - Special Functions*)

- **Arriving**

With motor valve drives, the temperature setpoint applicable at this point in time (e.g. time-controlled program) is restored.

Setpoint

Setting temperature

The valve drive can be set here to a certain setpoint temperature between 5 °C and 30 °C in 0.5 °C increments. First the current setpoint temperature is shown on the screen.

Set the new setpoint temperature directly with the numeric keypad or with "▲" and "▼" and then confirm your entry with "OK".

"Back" returns to the previous screen.

Note: If one of the functions Frost Protection, Party or Holiday is active, then this must first be deactivated.

Changing Setpoint

Increasing/decreasing

The temperature setpoint can be increased or decreased here between 0.5 K and 5 K (0.5 K increments). The increase or decrease applies temporarily until the next new temperature setpoint is received (e.g. by a program). Entering 0 sets the temperature to the original temperature setpoint again.

Party Function

When the Party function is activated, a temperature setpoint you have defined is permanently set for a certain time (1, 2, 3 or 4 hrs.), i.e. it is not overwritten by any other setpoint (e.g. from a time-controlled program).

The Party function ends after the set time ends or through manual switch-off.

Frost Protection

When the Frost Protection function is activated, a temperature setpoint you have defined (e.g. 10 °C) is permanently set, i.e. it is not overwritten by any other setpoint (e.g. from a time-controlled program). The Frost Protection function must be ended by switching it off manually. It is practical if you are away from home for more than 31 days. Otherwise it is advisable to use the Holiday function.

Maximum Limits

When programming the radio controller, the following maximum limits must be observed in addition to the loading in percent:

- Receivers: max. 60 light actuators (switching or dimming actuators)
 max. 60 blind actuators
 max. 30 motor valve drives

- Transmitters: Transmitter types: Hand-held transmitter, Mini hand-held transmitter, wall transmitter, multifunction transmitter, universal transmitter, observer, presence detector, smoke detector
 max. 60 radio transmitters per transmitter type per room

 Transmitter type: Room temperature sensors
 max. 60 room temperature sensors per radio controller

- Rooms: max. 60 rooms

- Programs: max. 60 programs
 A maximum of 60 switching times can be set per program.

- Links: max. 60 links
 A maximum of 60 conditions can be set per link.

Gira
Giersiepen GmbH & Co. KG
Electrical Installation Systems

Industriegebiet Mermbach
Dahlienstrasse
42477 Radevormwald

Postfach 1220
42461 Radevormwald

Tel.: +49 (0) 21 95- 602-0
Fax: +49 (0) 21 95- 602-339

www.gira.de
info@gira.de